

HS-magis40

CATALOGO TECNICO
TECHNICAL CATALOG

Produced with:
uni_one
TECHNOLOGY



ed. 01.12.2023

CT uni_one HS magis40-ver.11/01.12.2023





uni_one
TECHNOLOGY

ALZANTI
SCORREVOLI

LIFT &
SLIDE

HS-MAGIS40

DOPPIO VETRO $U_w=1,3 \text{ W/m}^2\text{K}$

TRIPLO VETRO $U_w=0,85 \text{ W/m}^2\text{K}$



Materiale		Legno-Alluminio
Isolamento termico		$U_w= 1,3 \text{ W/m}^2\text{K}$
Vetrocamera		Doppio vetro spessore 32mm
Isolamento termico		$U_w= 0,85 \text{ W/m}^2\text{K}$
Vetrocamera		Tripla vetro spessore 52mm
Isolamento acustico		Rw fino a 38 dB
Ferramenta di sicurezza		Fino a RC2
Permeabilità all'Aria		CLASSE 4
Tenuta all'Acqua		CLASSE 9A
Resistenza al carico del Vento		CLASSE C4/B5
Resistenza per altezze $\geq 2,4\text{mt}$		CLASSE C1/B2
<p>I valori di isolamento termico sono calcolati secondo la norma UNI EN 10077/1-2018, UNI EN 10077/2-2018, UNI EN 10456-2008, UNI EN 673-2011, in riferimento ad un alzante scorrevole Schema A - LxH (2800x2400mm, $\psi_g= 0,04 \text{ W/m}^2\text{K}$)</p>		
<p>Le prestazioni aria-acqua-vento sono certificate in riferimento ad un alzante scorrevole Schema A - LxH (2800x2400mm)</p>		
<p>Resistenza al carico del vento per altezza $\geq 2,4\text{mt}$ certificata in riferimento ad un alzante scorrevole Schema A - LxH (4000x3200mm)</p>		
<p>Isolamento acustico certificato in riferimento ad un alzante scorrevole Schema A - LxH (3560x2960mm) doppio vetro con $R_w= 44 \text{ (-2;-7) dB}$</p>		

HS-MAGIS40 - vetro 32mm LEGNO TENERO (SOFT WOOD)

$U_g \text{ W/m}^2\text{K}$	$U_w \text{ W/m}^2\text{K}$
1,0	-> 1,3
1,1	-> 1,4
1,2	-> 1,5
1,3	-> 1,6
1,4	-> 1,7
1,5	-> 1,8
1,6	-> 1,8

HS-MAGIS40 - vetro 52mm LEGNO TENERO (SOFT WOOD)

$U_g \text{ W/m}^2\text{K}$	$U_w \text{ W/m}^2\text{K}$
0,5	-> 0,85
0,6	-> 0,95
0,7	-> 1,0
0,8	-> 1,1
0,9	-> 1,2
1,0	-> 1,3
1,1	-> 1,4

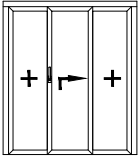
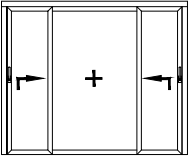
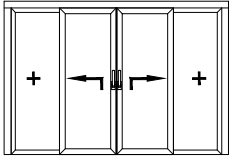
				
	Schema A	Schema G	Schema K	Schema F
vetro 32mm	✓	✓	✓	✓
vetro 52mm	✓	✓	✓	✓

Indice generale/General index

Fattibilità <i>Types of opening</i>	pag.2
Scheda tecnica <i>Technical data sheet</i>	pag.3
Disegni tecnici/ <i>Technical drawings:</i> uni_one HS40 con doppio vetro(<i>Double glazing</i>)	pag.5
uni_one HS40 con triplo vetro(<i>Triple glazing</i>)	pag.11
Esempi di posa <i>Installation</i>	pag.17
Apertura automatizzata <i>Automatic drive system</i>	pag.27
Altre tipologie di apertura <i>Other opening types</i>	pag.28
Prospetti/viste <i>Views</i>	pag.36
Istruzioni di montaggio <i>Assembly instructions</i>	pag.37
Riepiloghi <i>Summary</i>	pag.69

Limiti dimensionali per anta scorrevole
Portata massima ≤ 400 Kg

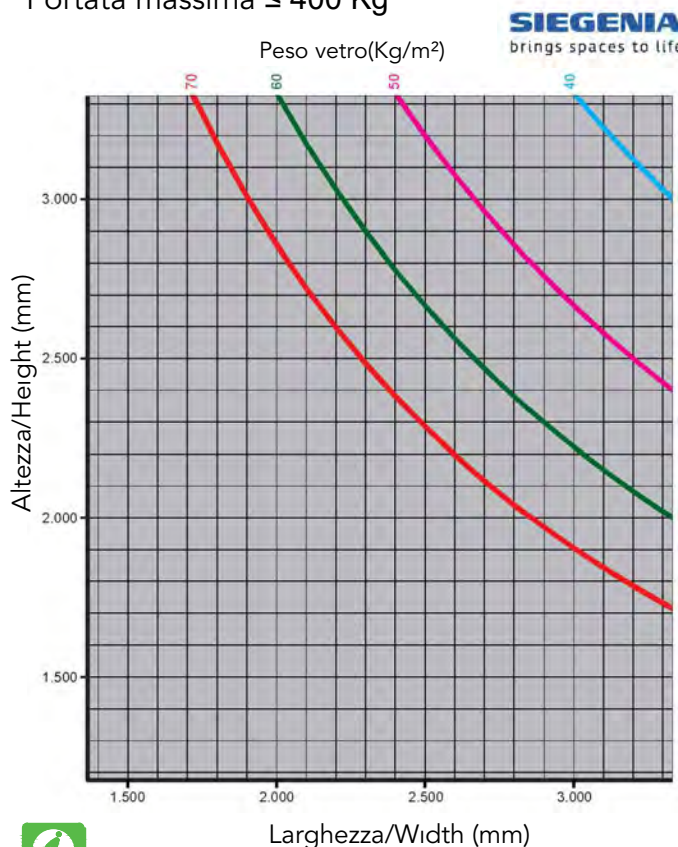

Per i profili legno, alluminio e per il profilo soglia la lunghezza massima delle barre è di 6 mt.

uni_one 90°
HS magis40 - Kit uniform
Doppio vetro



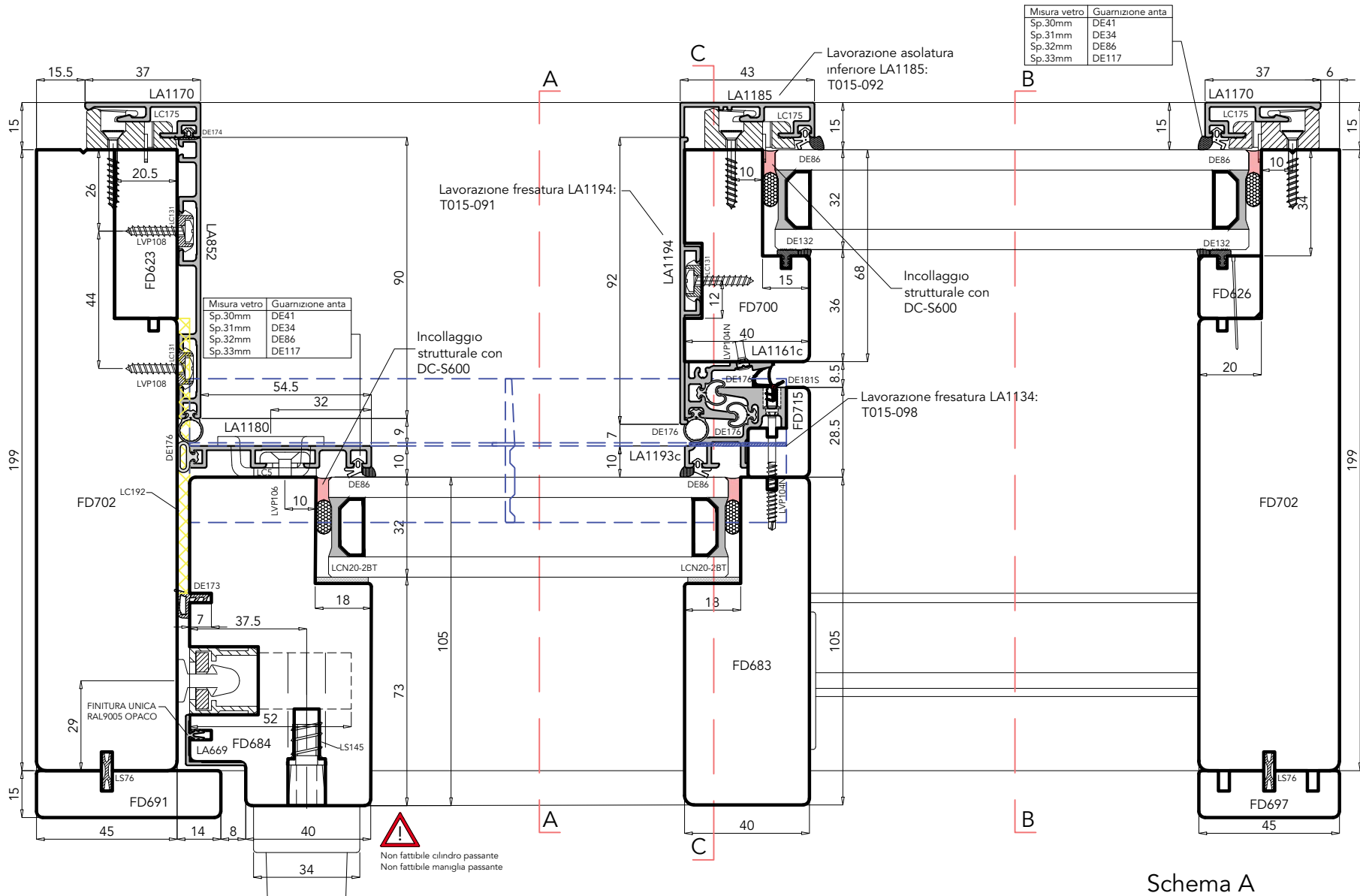

uni_one90° HS magis40 - Doppio vetro

uniform

Zoom 55%

- (IT) Sezione orizzontale serramento alzante scorrevole
- (DE) Horizontalschnitt Hebe-Schiebe-Tür
- (ES) Sección horizontal corredera elevadora
- (FR) Coupe horizontale fenêtre levante-coulissante
- (UK) Horizontal section of sliding window-door

Schema A

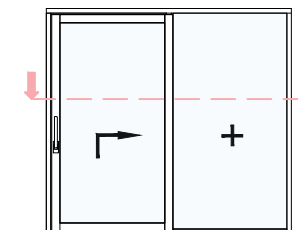

VARIANTE CON ANTA CON MANIGLIONE
INTERNO/ESTERNO E SERRATURA

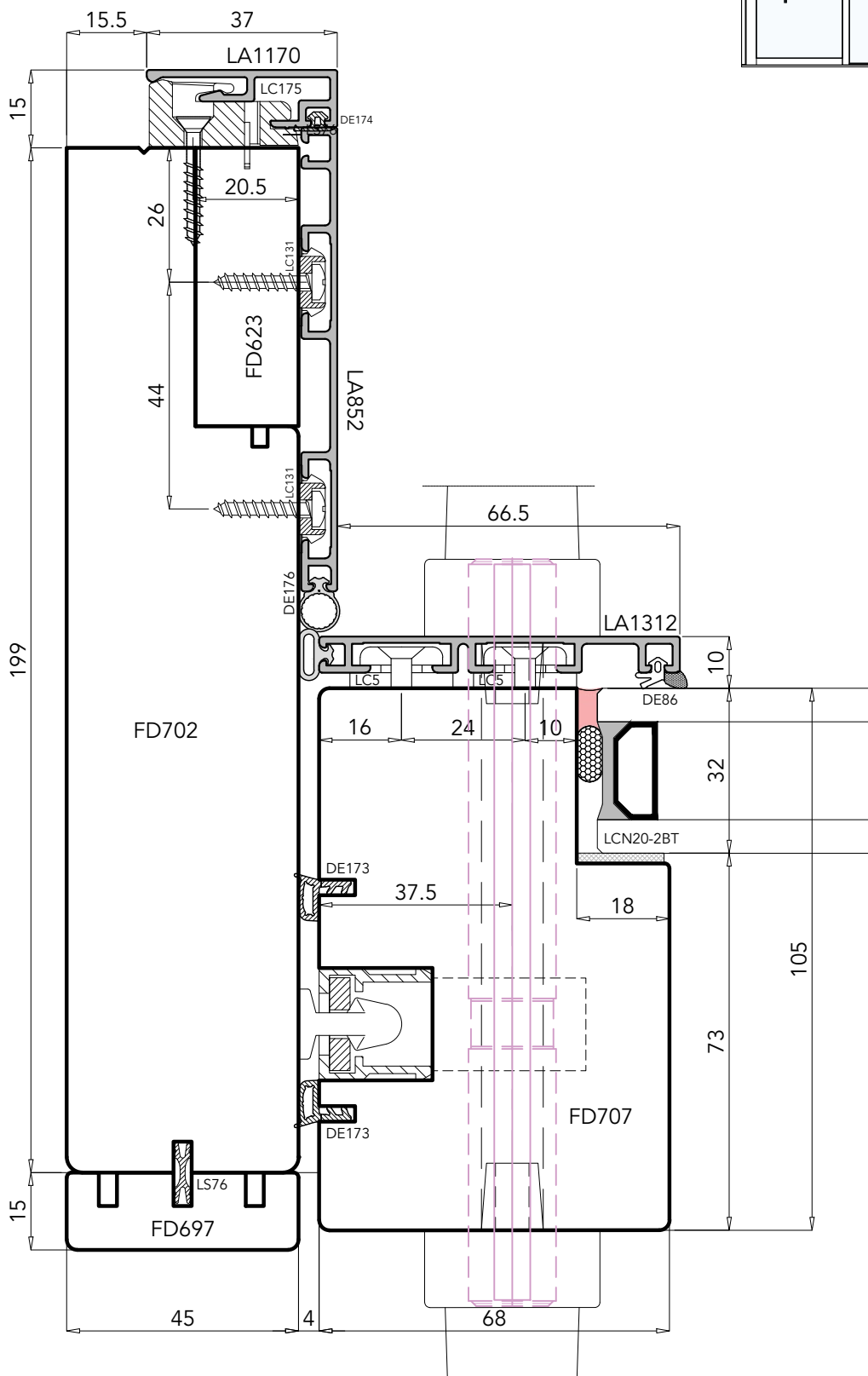
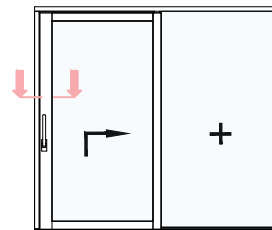

uni_one90° HS magis40 - Doppio vetro

uniform

Zoom 80%

- (IT) Sezione orizzontale serramento alzante scorrevole
- (DE) Horizontalschnitt Hebe-Schiebe-Tür
- (ES) Sección horizontal corredera elevadora
- (FR) Coupe horizontale fenêtre levante-coulissante
- (UK) Horizontal section of sliding window-door

Sez. B-B

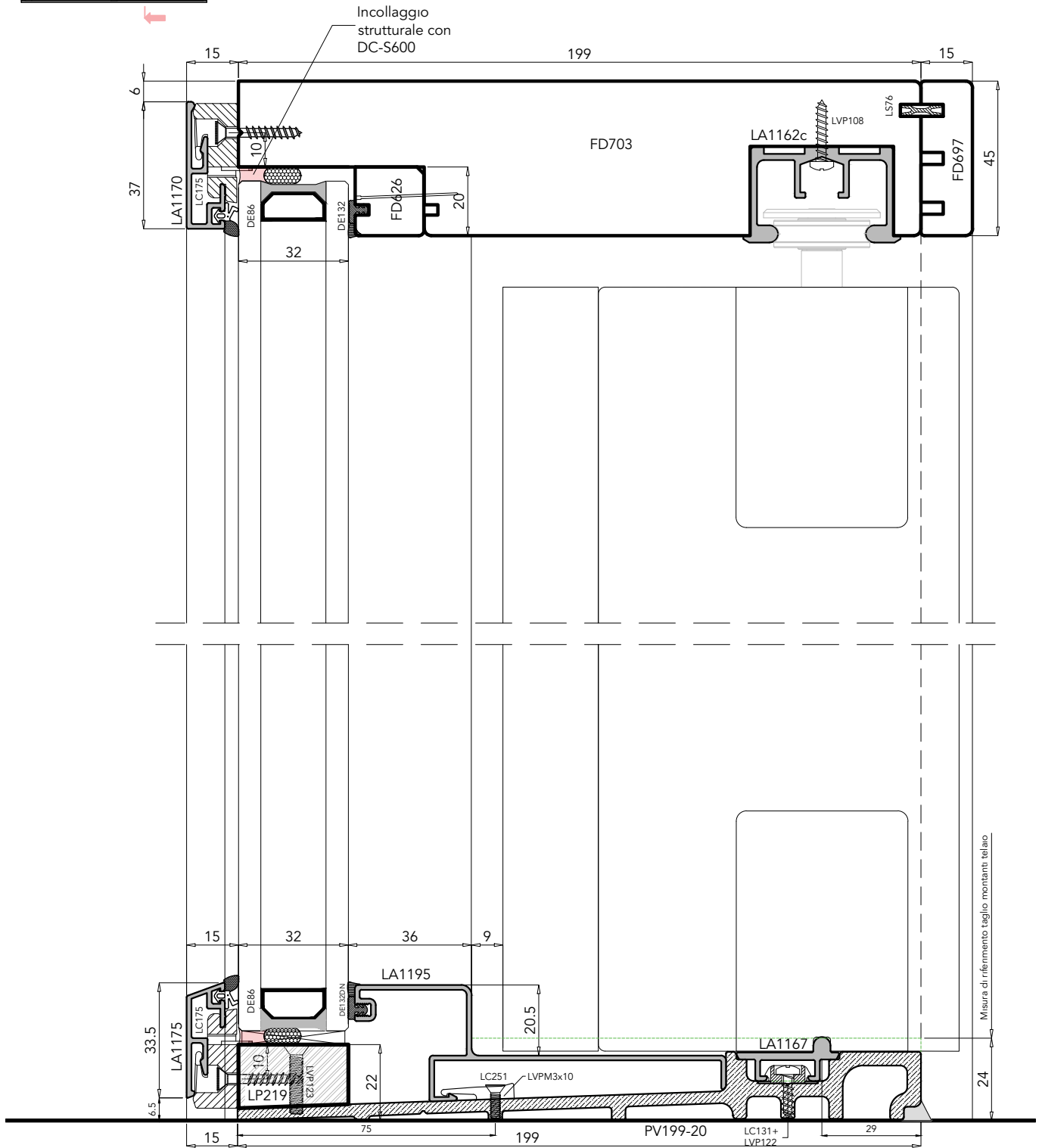
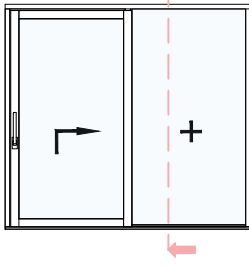

uni_one90° HS magis40 - Doppio vetro



Zoom 60%

- (IT) Sezione verticale serramento alzante scorrevole
- (DE) Vertikalschnitt Hebe-Schiebe-Tür
- (ES) Sección vertical corredera elevadora
- (FR) Coupe verticale fenêtre levante-coulissante
- (UK) Vertical section of sliding window-door

uni_one 90°
HS magis40 - Kit uniform
Triplo vetro



VARIANTE CON ANTA CON MANIGLIONE INTERNO/ESTERNO E SERRATURA

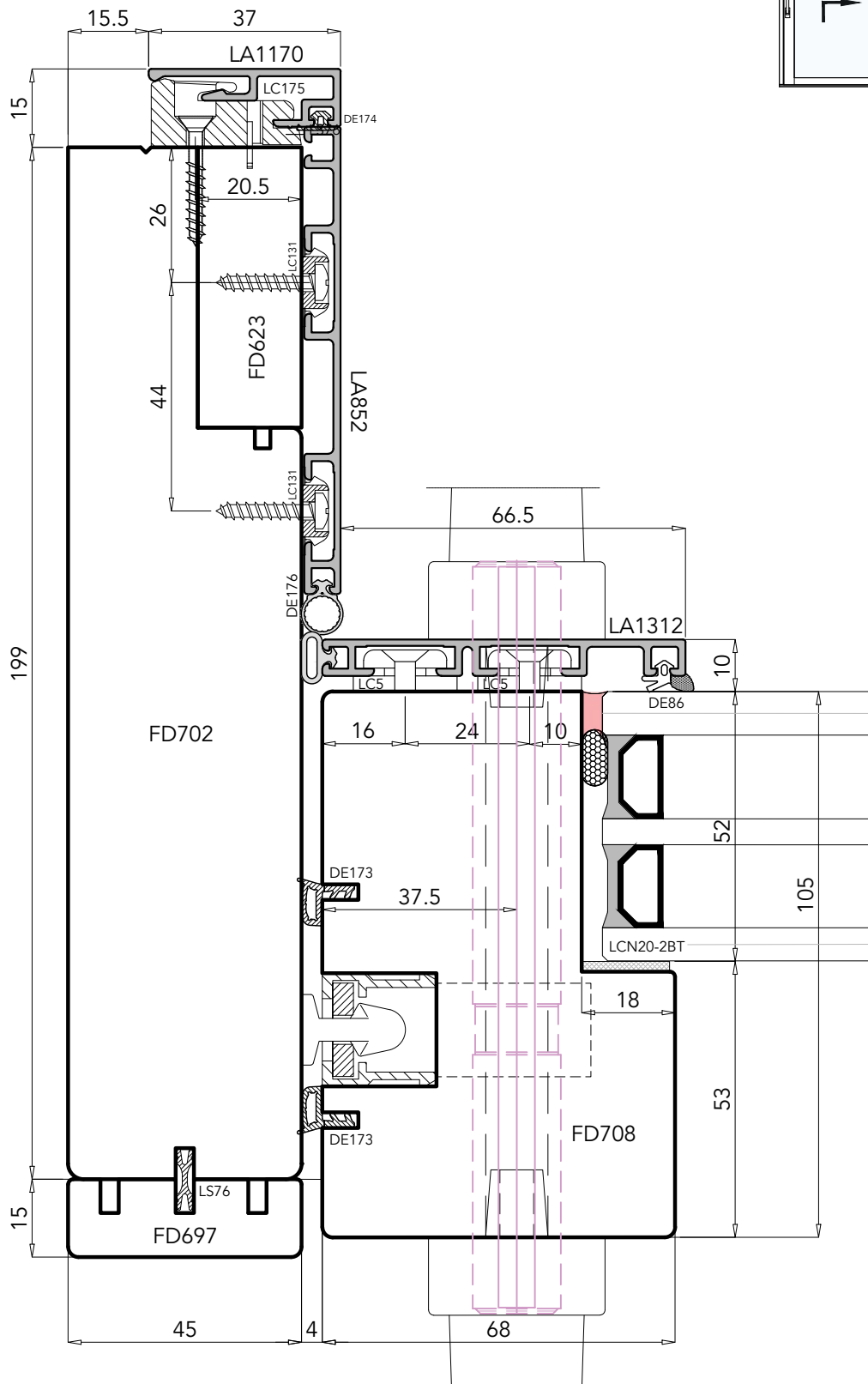
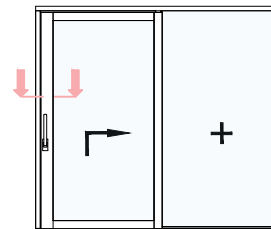

uni_one90° HS magis40 - Triplo vetro

uniform

Zoom 80%

- (IT) Sezione orizzontale serramento alzante scorrevole
- (DE) Horizontalschnitt Hebe-Schiebe-Tür
- (ES) Sección horizontal corredera elevadora
- (FR) Coupe horizontale fenêtre levante-coulissante
- (UK) Horizontal section of sliding window-door

Sez. B-B

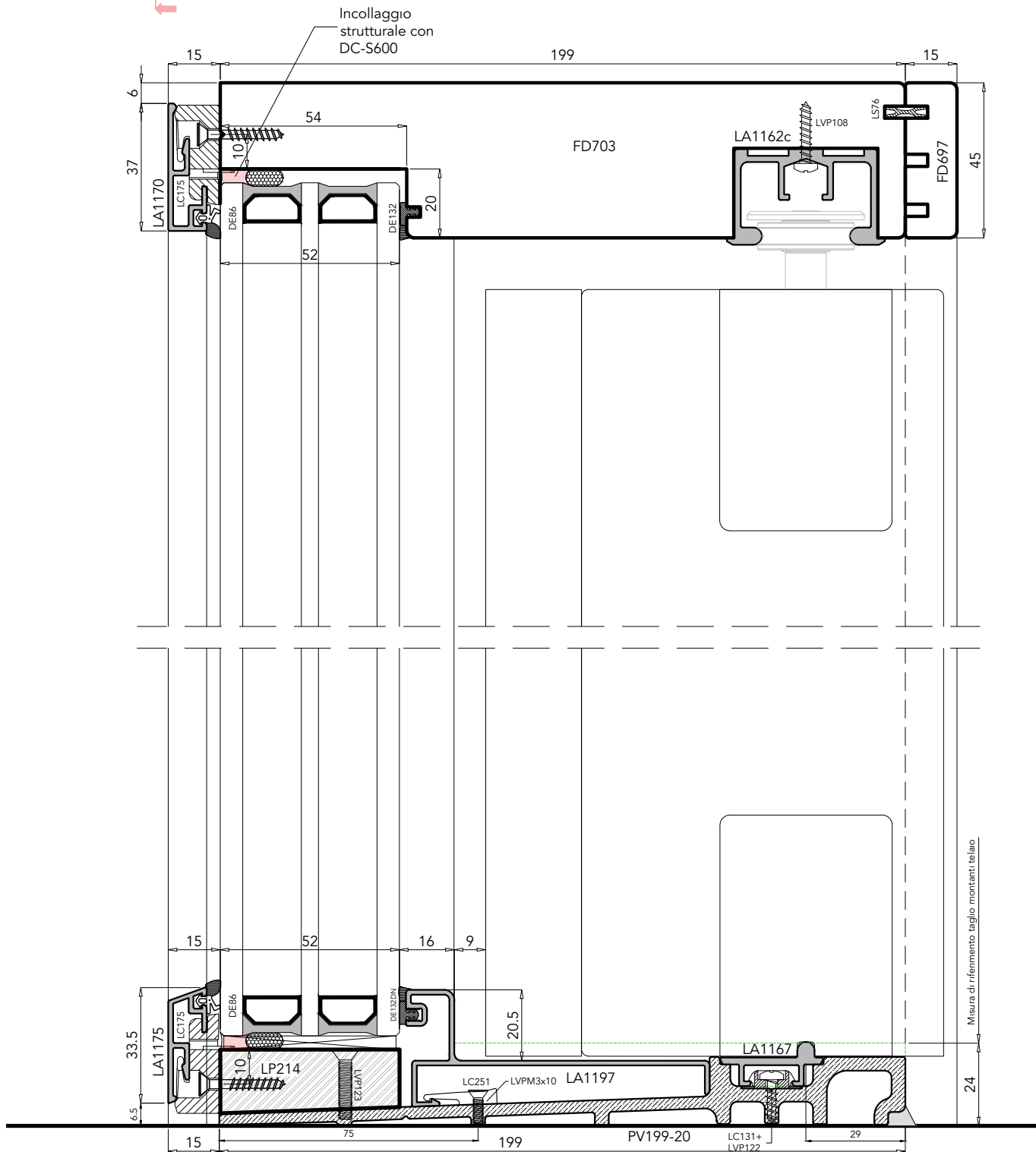
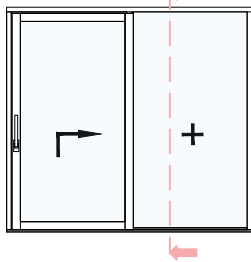

uni_one90° HS magis40 - Triplo vetro



Zoom 60%

- (IT) Sezione verticale serramento alzante scorrevole
- (DE) Vertikalschnitt Hebe-Schiebe-Tür
- (ES) Sección vertical corredera elevadora
- (FR) Coupe verticale fenêtre levante-coulissante
- (UK) Vertical section of sliding window-door

Soluzione B - Posa con raso muro a filo interno con finitura ad intonaco



Muratura/
Mattone forato

Sigillatura
Controtelaio
in legno

Sigillatura

Intonaco di
finitura

Profilo porta intonaco in
PVC (Art. 2762
Produttore: 3ks profile)

Profilo in
alluminio
LA694c

Guarda il video istruzioni di posa:



uni_one90° HS magis40

uniform

Scala -

- (IT) Sezione orizzontale serramento alzante scorrevole
- (DE) Horizontalschnitt Hebe-Schiebe-Tür
- (ES) Sección horizontal corredera elevadora
- (FR) Coupe horizontale fenêtre levante-coulissante
- (UK) Horizontal section of sliding window-door

Schema A

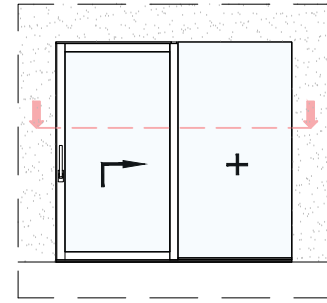

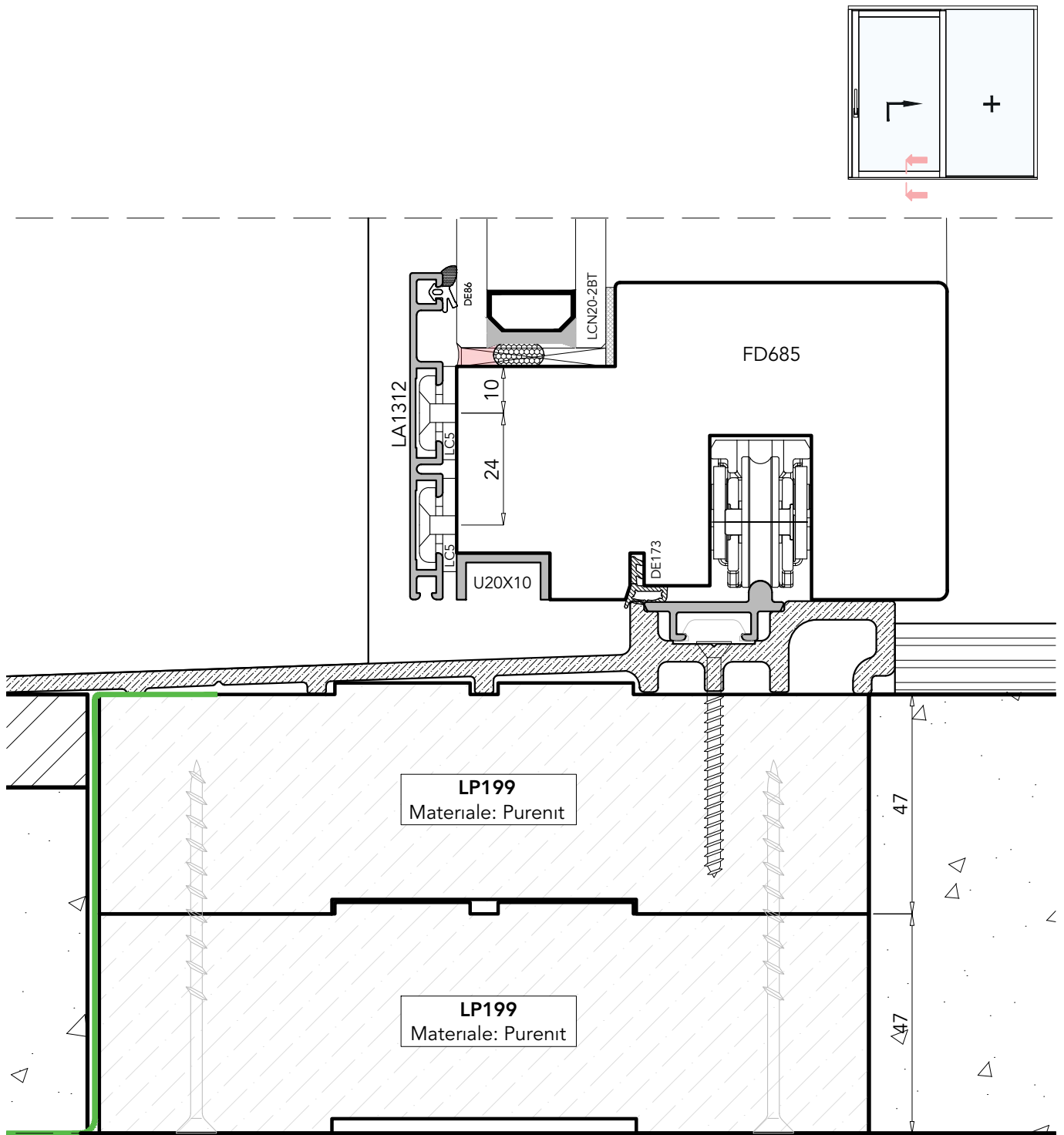

uni_one90° HS magis40

uniform

Zoom 80%

- (IT) Sezione verticale serramento alzante scorrevole
- (DE) Vertikalschnitt Hebe-Schiebe-Tür
- (ES) Sección vertical corredera elevadora
- (FR) Coupe verticale fenêtre levante-coulissante
- (UK) Vertical section of sliding window-door

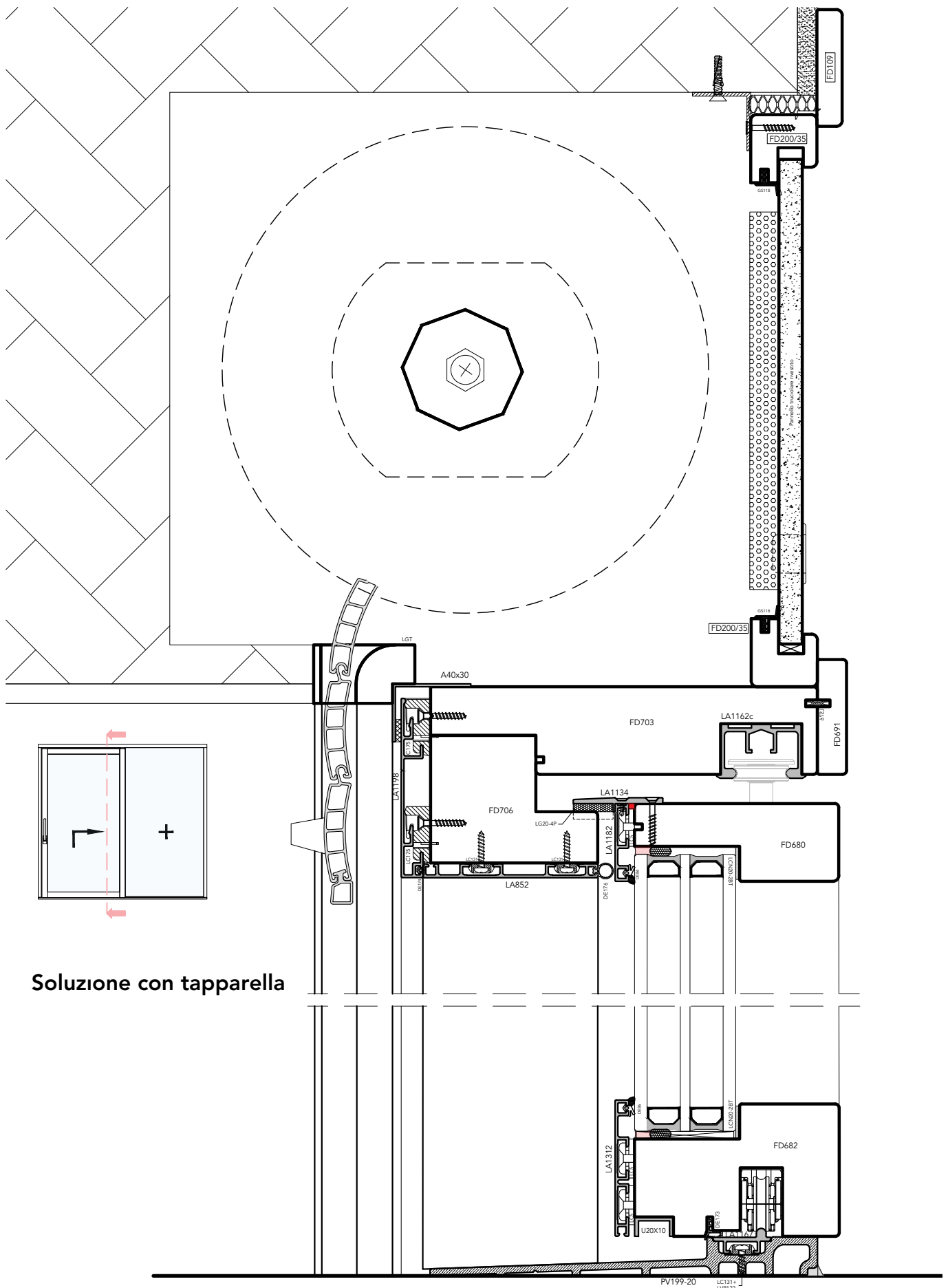

Soluzione con tapparella

uni_one90° HS magis40

uniform

Scala -

- (IT) Sezione verticale serramento alzante scorrevole
- (DE) Vertikalschnitt Hebe-Schiebe-Tür
- (ES) Sección vertical corredera elevadora
- (FR) Coupe verticale fenêtre levante-coulissante
- (UK) Vertical section of sliding window-door

Soluzione con zanzariera a scorrimento laterale modello Plana

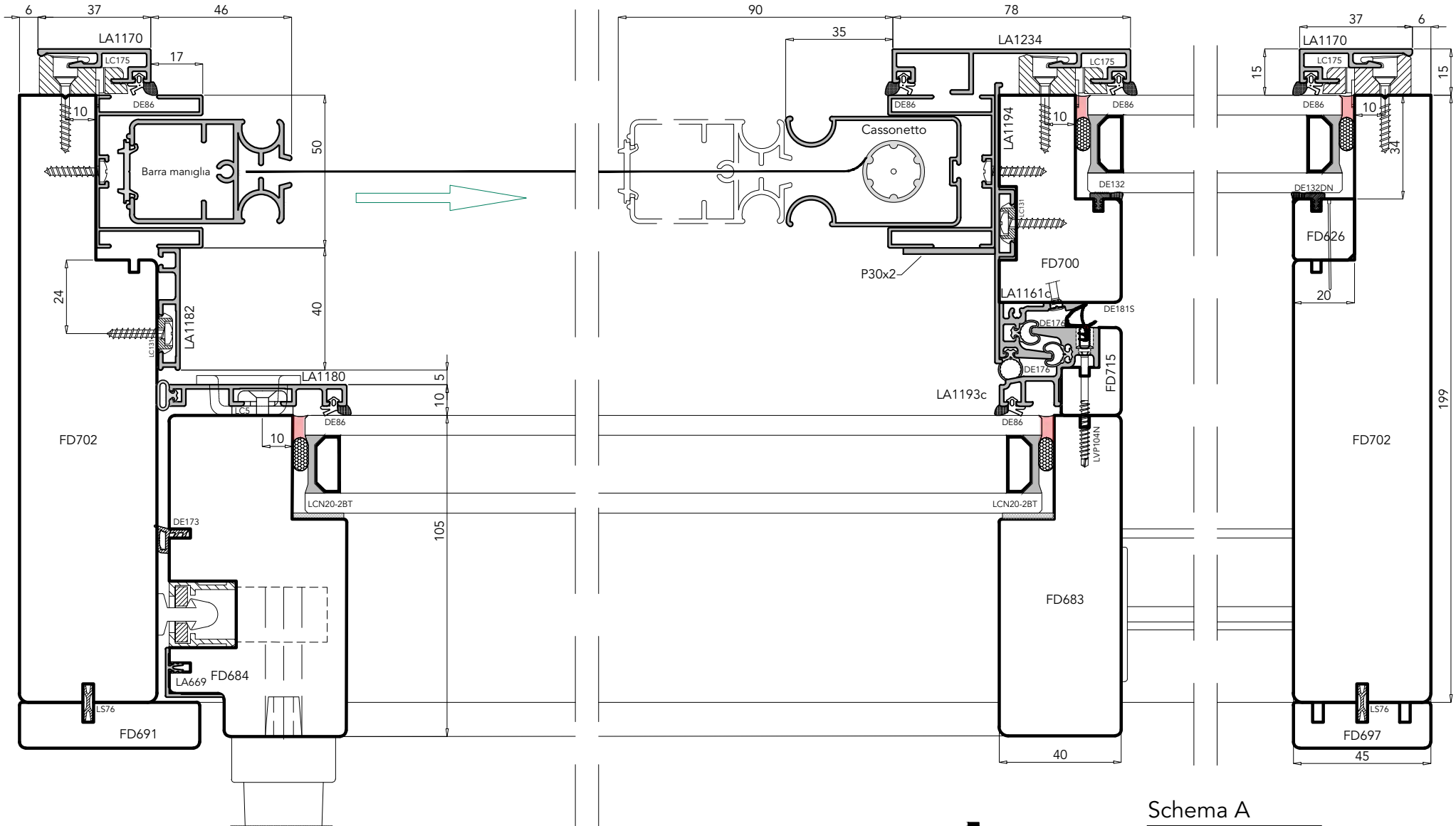

uni_one90° HS magis40

uniform

Scala -

- (IT) Sezione orizzontale serramento alzante scorrevole
- (DE) Horizontalschnitt Hebe-Schiebe-Tür
- (ES) Sección horizontal corredera elevadora
- (FR) Coupe horizontale fenêtre levante-coulissante
- (UK) Horizontal section of sliding window-door

Schema A

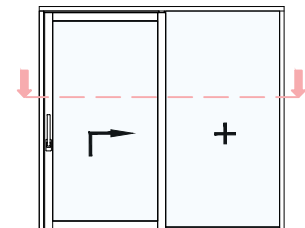

Soluzione con zanzariera a scorrimento laterale modello Plana

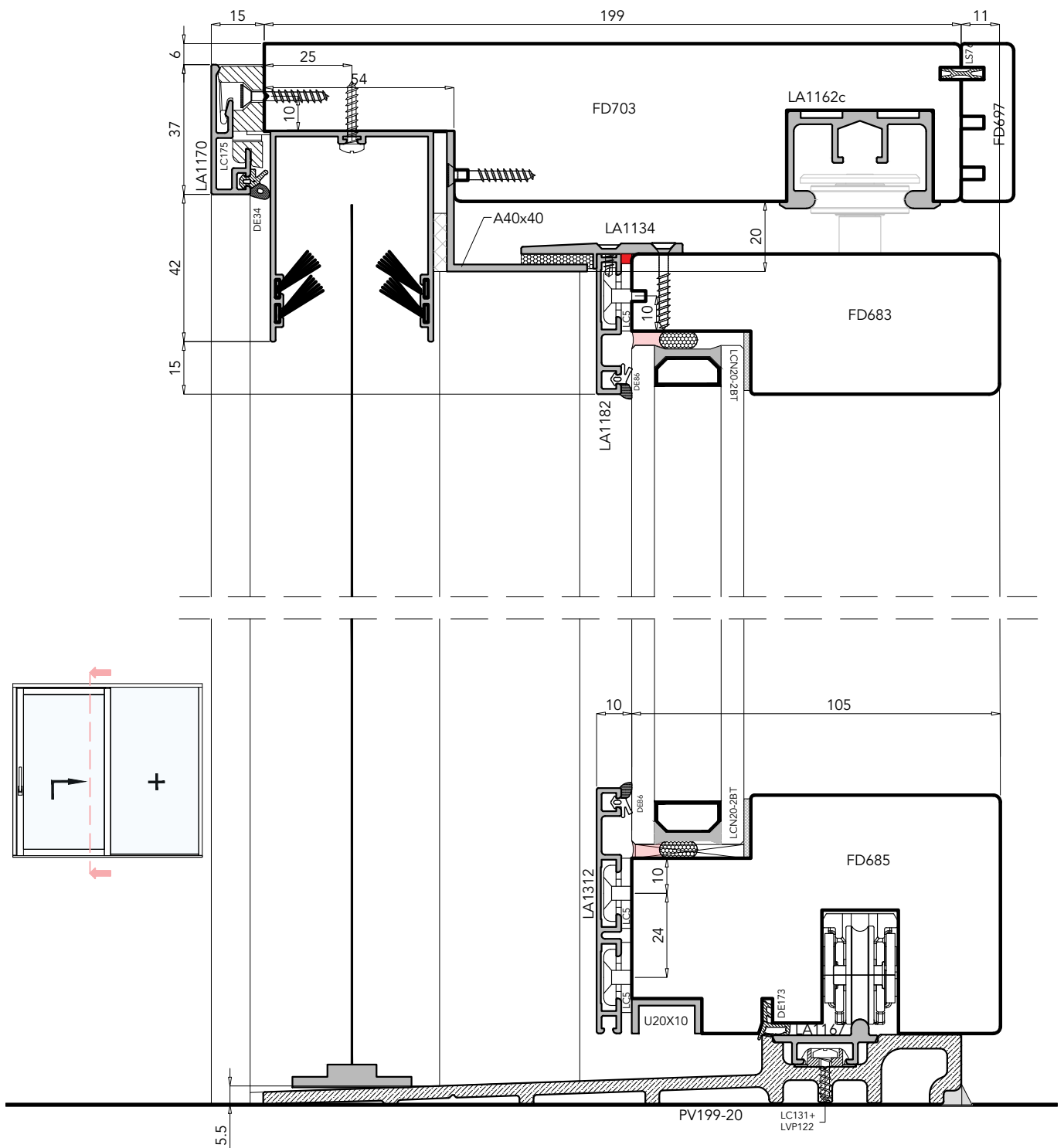

uni_one90° HS magis40

uniform

Zoom 60%

- (IT) Sezione verticale serramento alzante scorrevole
- (DE) Vertikalschnitt Hebe-Schiebe-Tür
- (ES) Sección vertical corredera elevadora
- (FR) Coupe verticale fenêtre levante-coulissante
- (UK) Vertical section of sliding window-door

Soluzione con zanzariera a scorrimento laterale modello Plana

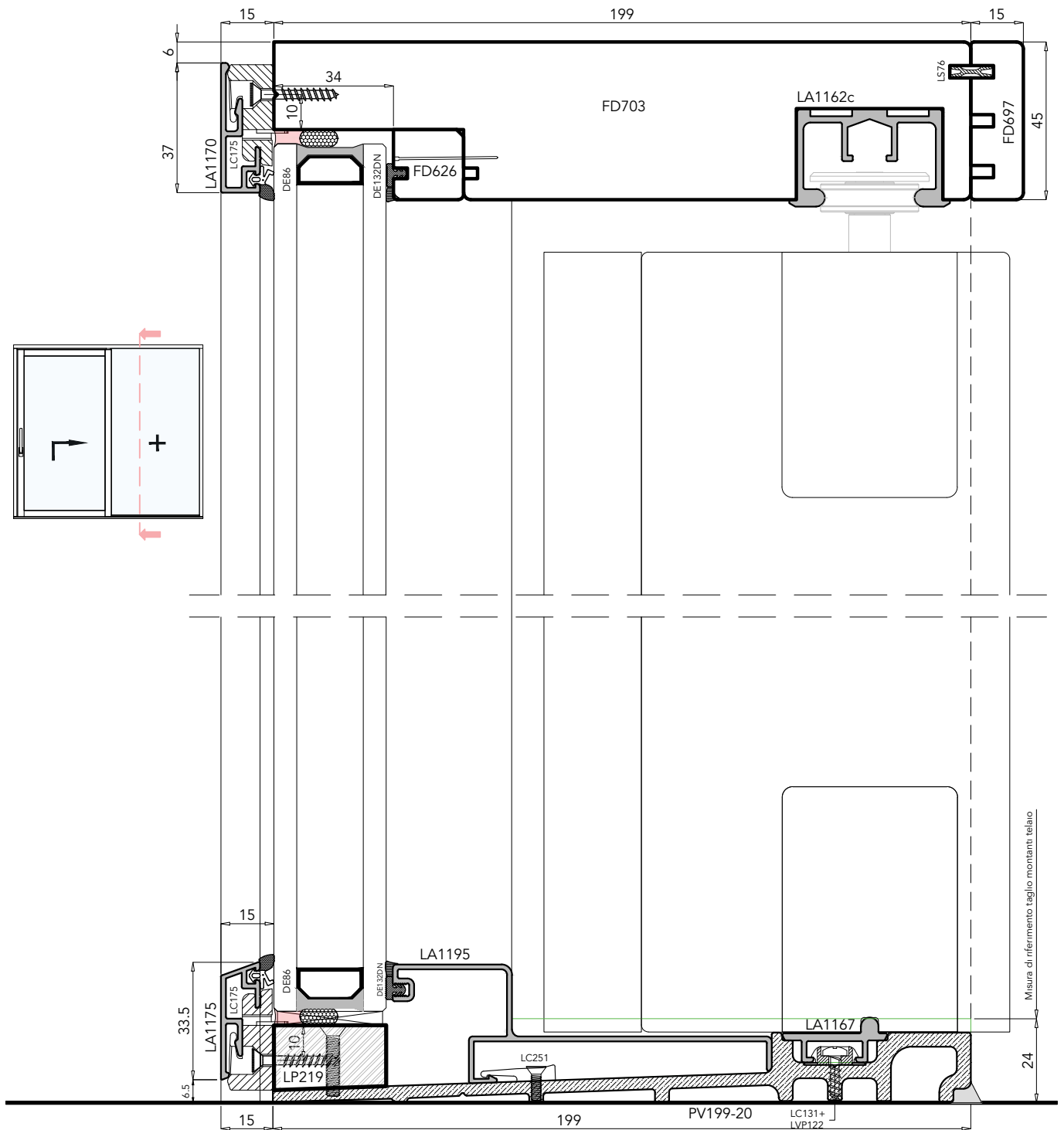

uni_one90° HS magis40

uniform

Zoom 60%

- (IT) Sezione verticale serramento alzante scorrevole
- (DE) Vertikalschnitt Hebe-Schiebe-Tür
- (ES) Sección vertical corredera elevadora
- (FR) Coupe verticale fenêtre levante-coulissante
- (UK) Vertical section of sliding window-door

Automazione per apertura dell'anta
Particolare montaggio del motore da applicare superiore

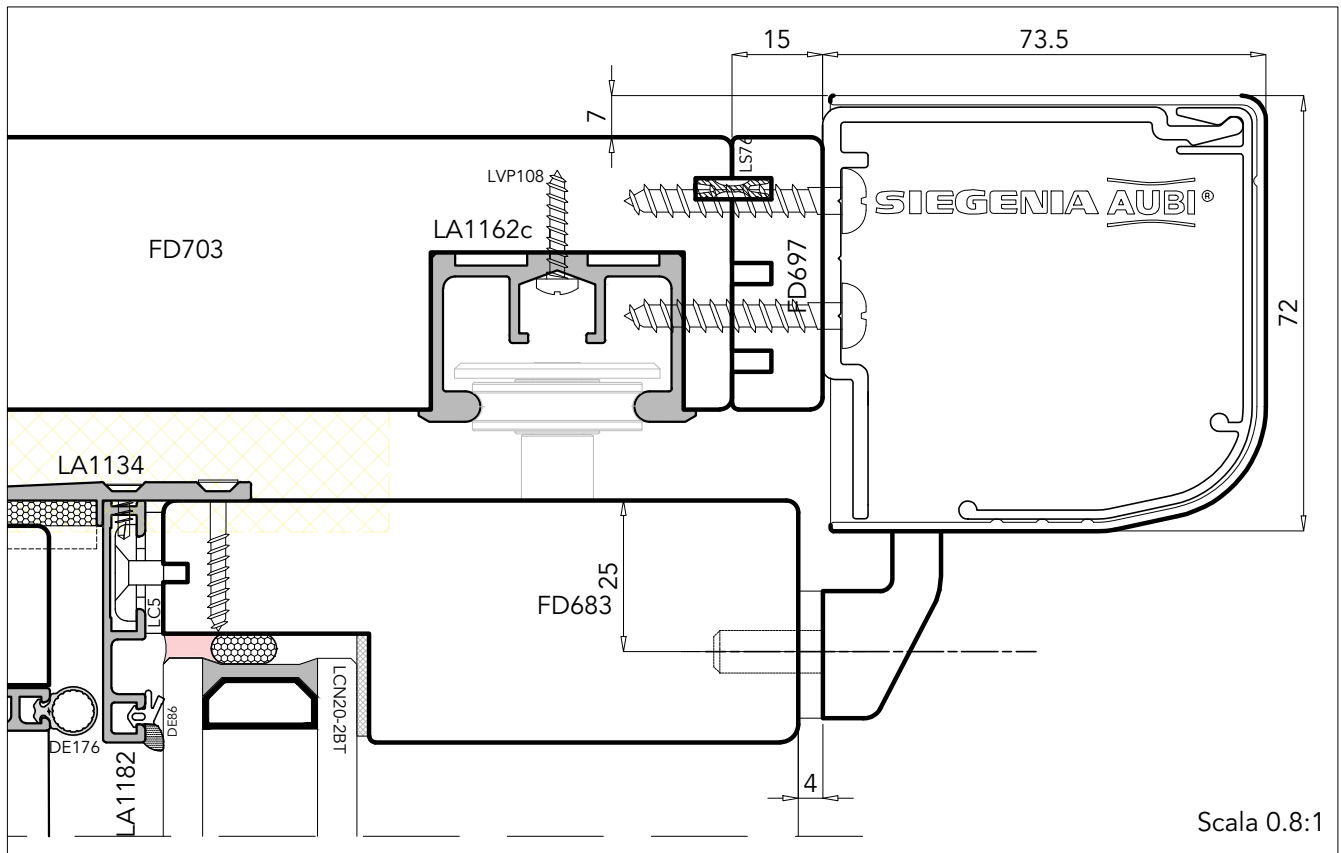
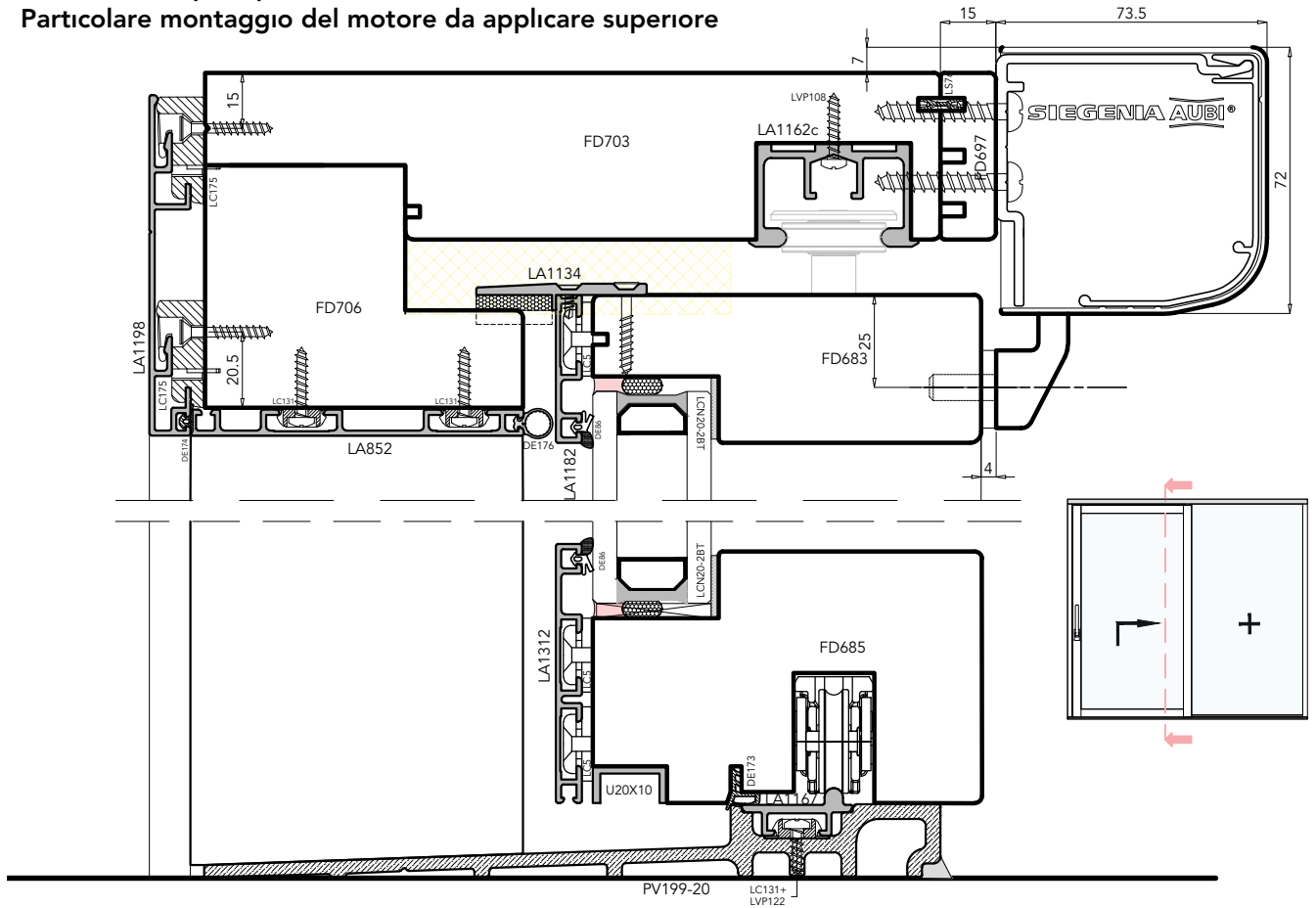

uni_one90° HS magis40

uniform

Scala -

- (IT) Sezione verticale serramento alzante scorrevole
- (DE) Vertikalschnitt Hebe-Schiebe-Tür
- (ES) Sección vertical corredera elevadora
- (FR) Coupe verticale fenêtre levante-coulissante
- (UK) Vertical section of sliding window-door

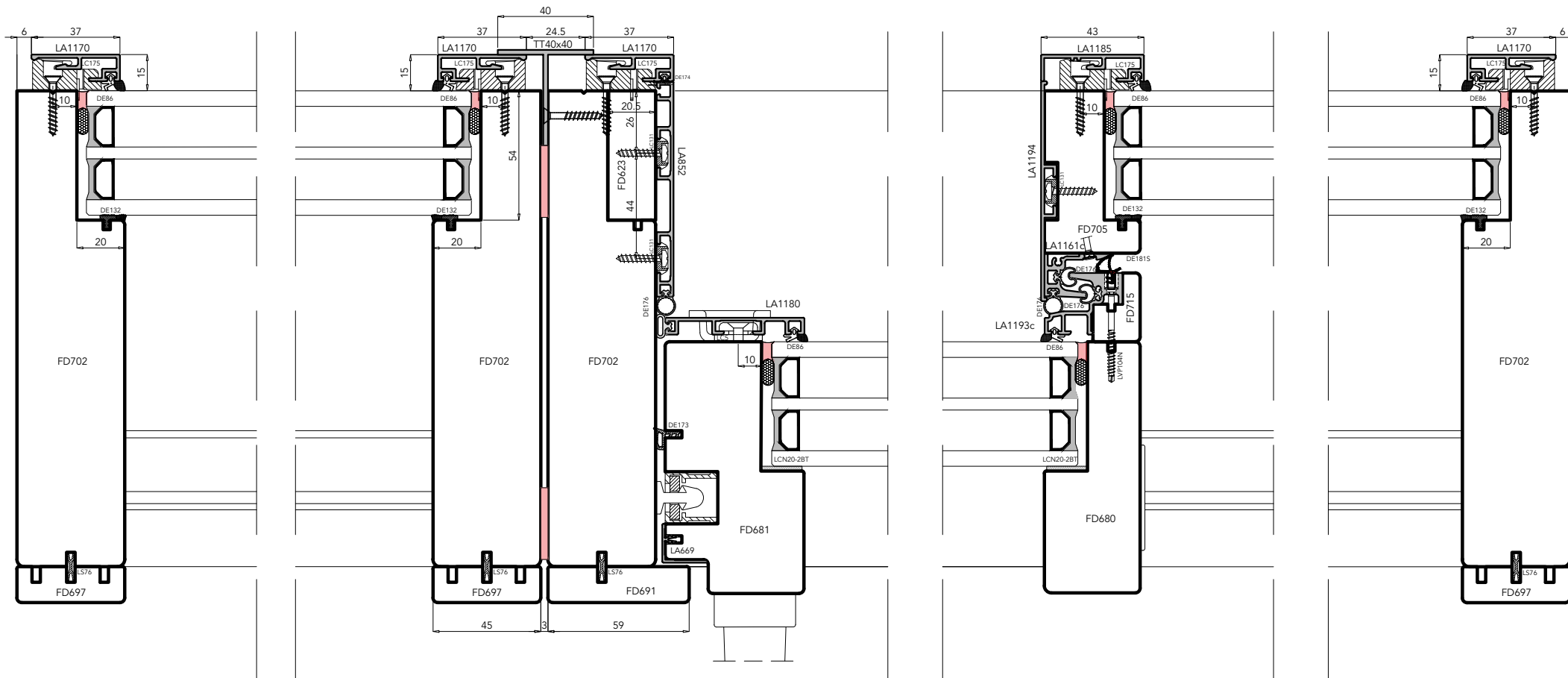

uni_one90° HS magis40

uniform

Scala -

- (IT) Sezione orizzontale serramento alzante scorrevole
- (DE) Horizontalschnitt Hebe-Schiebe-Tür
- (ES) Sección horizontal corredera elevadora
- (FR) Coupe horizontale fenêtre levante-coulissante
- (UK) Horizontal section of sliding window-door

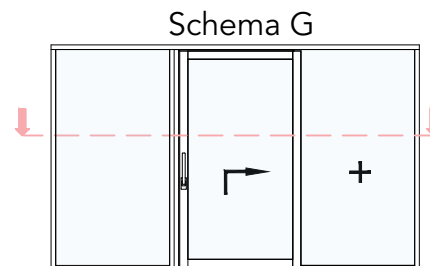

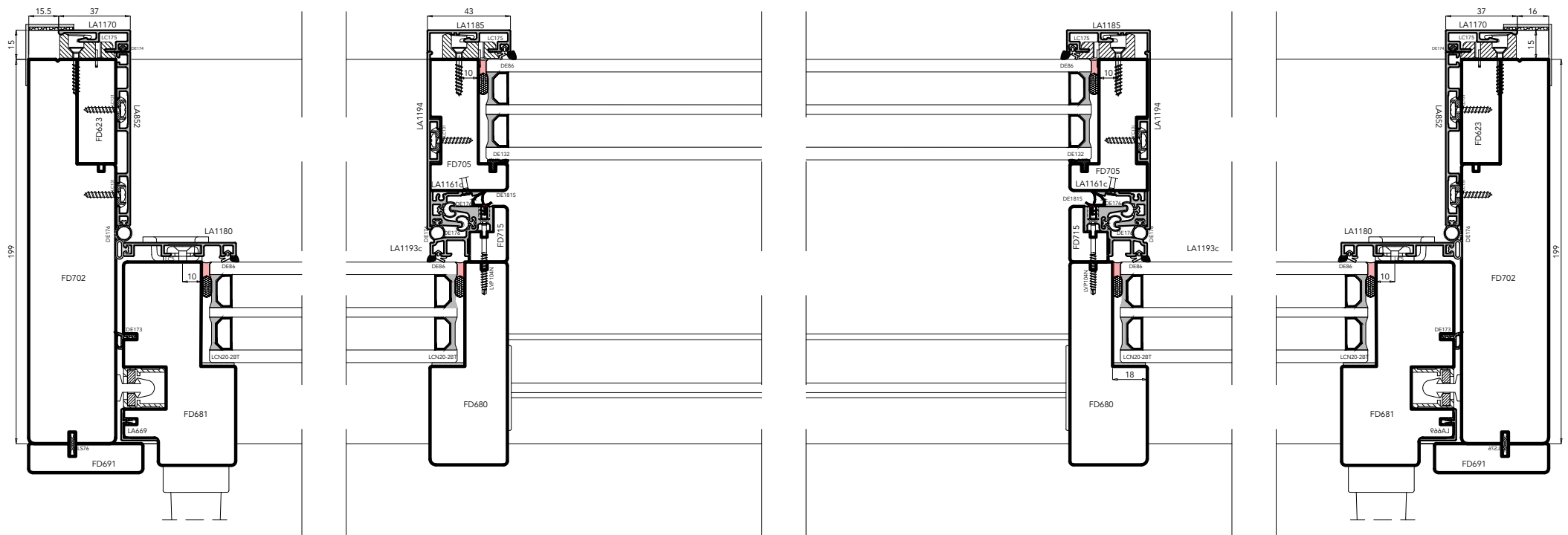

uni_one90° HS magis40

uniform

Scala -

- (IT) Sezione orizzontale serramento alzante scorrevole
- (DE) Horizontalschnitt Hebe-Schiebe-Tür
- (ES) Sección horizontal corredera elevadora
- (FR) Coupe horizontale fenêtre levante-coulissante
- (UK) Horizontal section of sliding window-door

Schema K

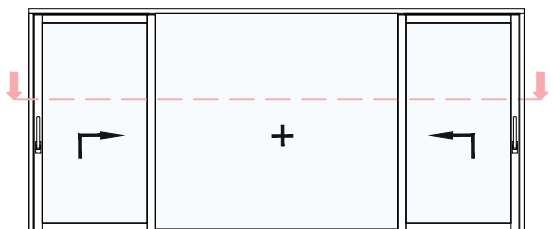

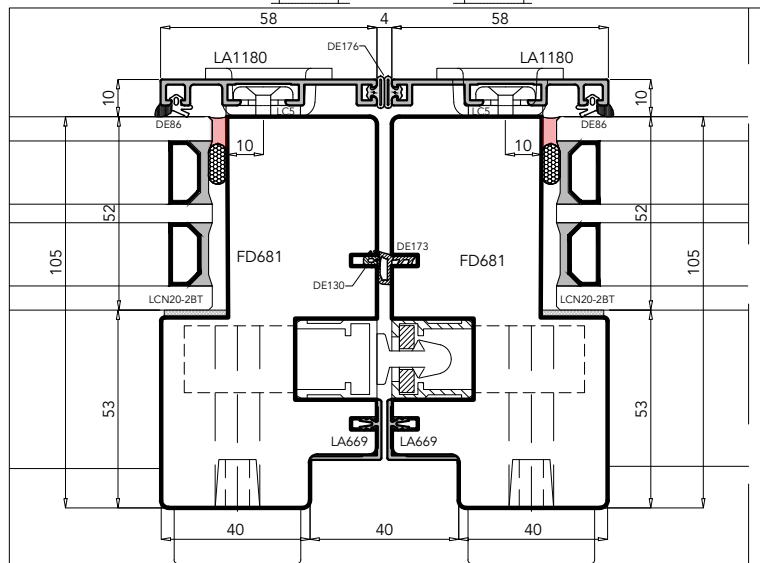
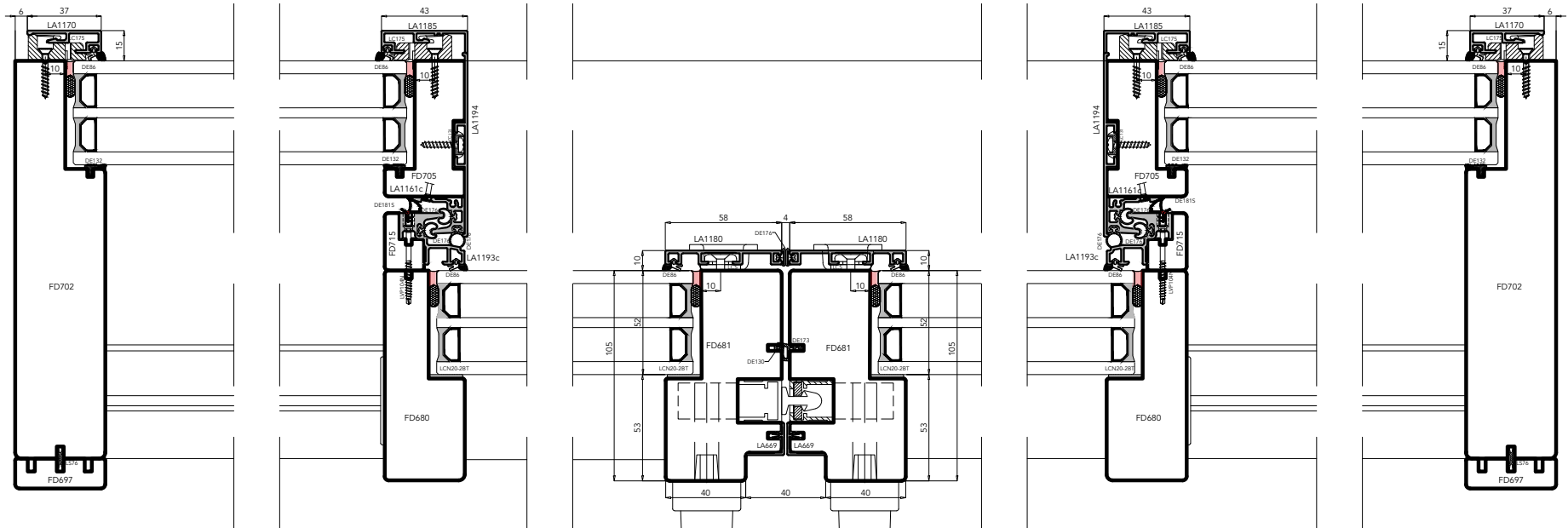

uni_one90° HS magis40

uniform

Scala -

- (IT) Sezione orizzontale serramento alzante scorrevole
- (DE) Horizontalschnitt Hebe-Schiebe-Tür
- (ES) Sección horizontal corredera elevadora
- (FR) Coupe horizontale fenêtre levante-coulissante
- (UK) Horizontal section of sliding window-door

Schema F

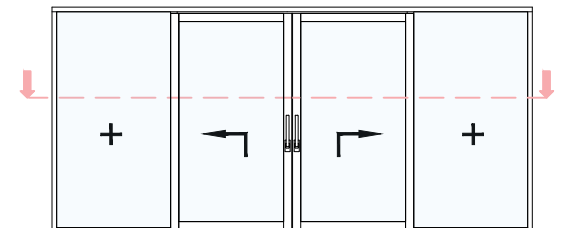

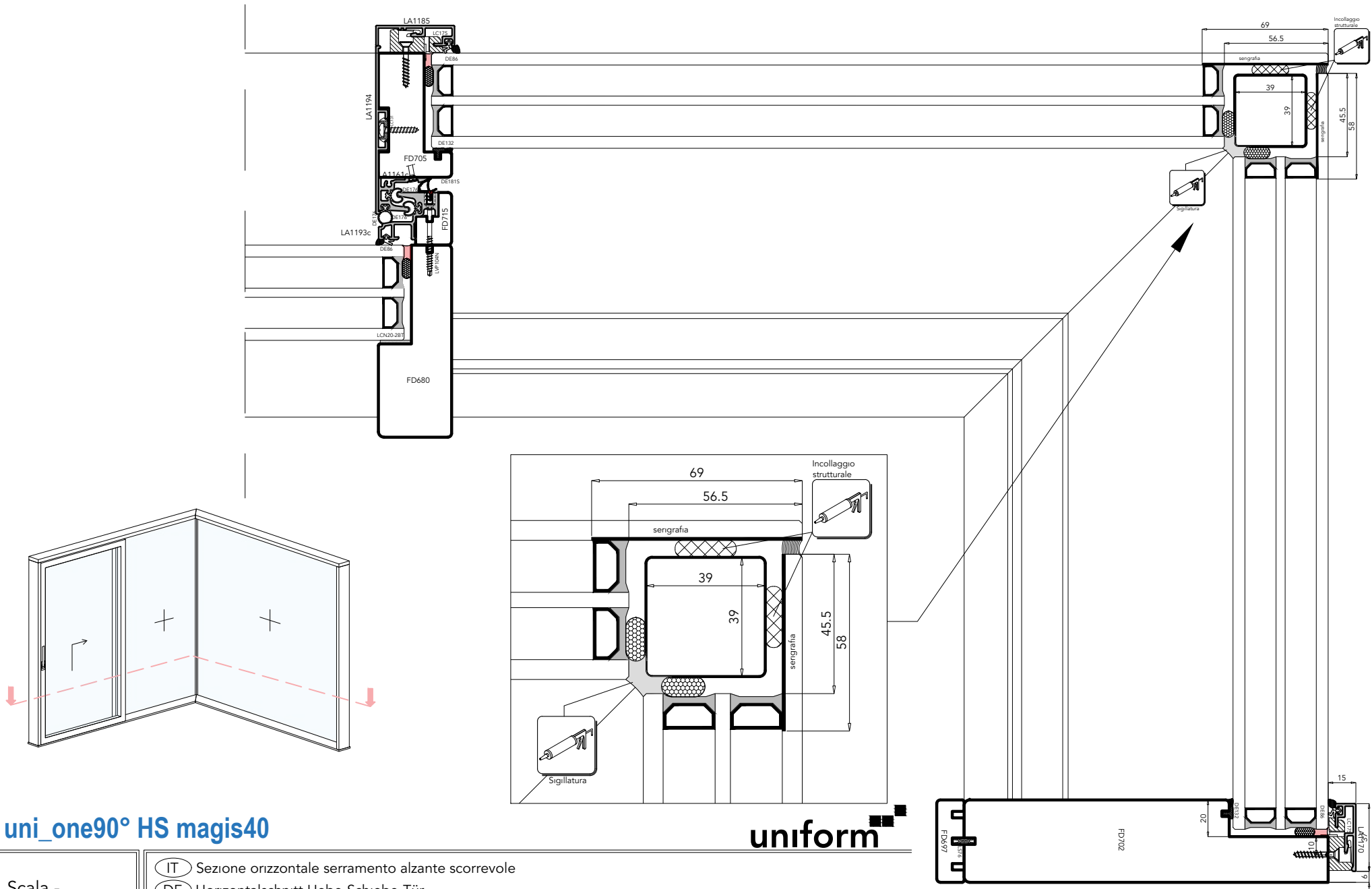

uni_one90° HS magis40

Scala -

- (IT) Sezione orizzontale serramento alzante scorrevole
- (DE) Horizontalschnitt Hebe-Schiebe-Tür
- (ES) Sección horizontal corredera elevadora
- (FR) Coupe horizontale fenêtre levante-coulissante
- (UK) Horizontal section of sliding window-door

uniform

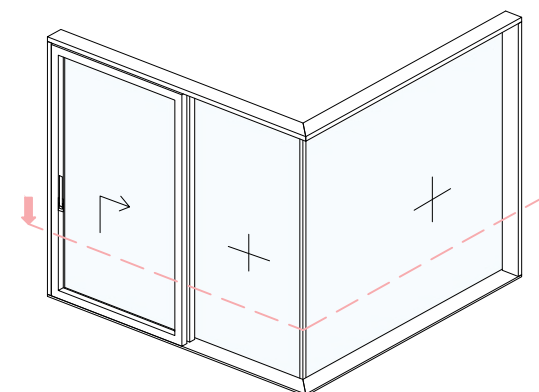
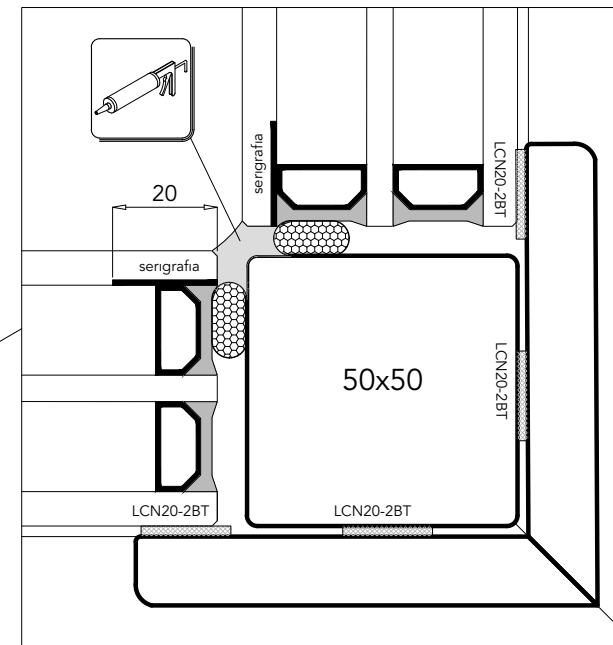
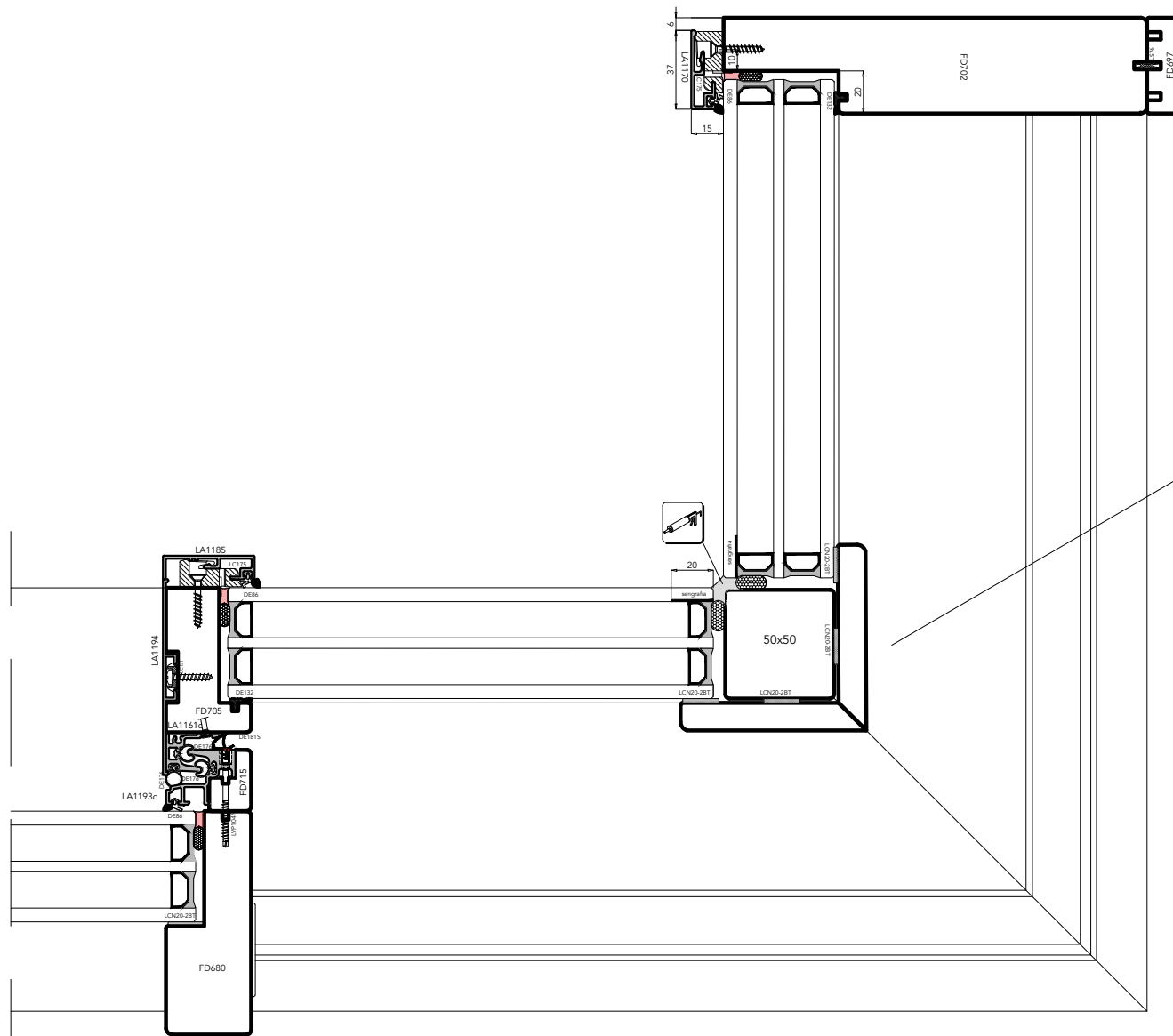

uni_one90° HS magis40

uniform

Scala -

- (IT) Sezione orizzontale serramento alzante scorrevole
- (DE) Horizontalschnitt Hebe-Schiebe-Tür
- (ES) Sección horizontal corredera elevadora
- (FR) Coupe horizontale fenêtre levante-coulissante
- (UK) Horizontal section of sliding window-door

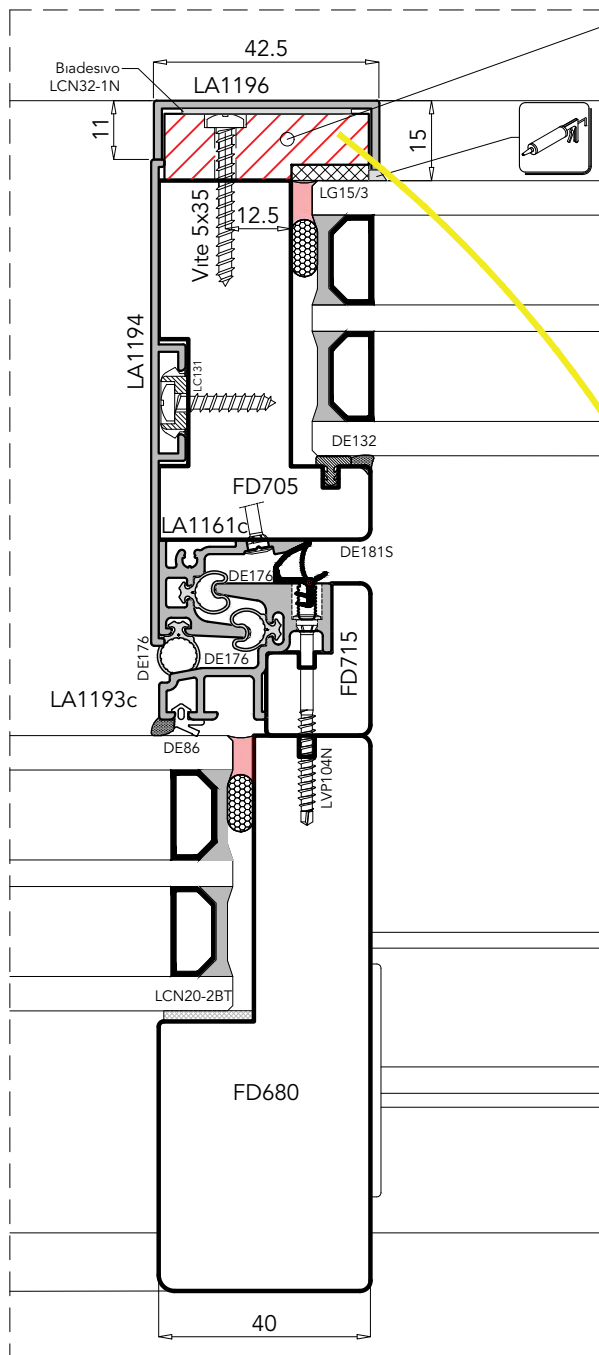

LS151:
Rinforzo in acciaio zincato
Misura min. 2500/Max. 3200mm
con foratura passo 300mm

Certificazione resistenza al carico del vento(EN 12211 e UNI EN 12210):

C1/B2

Test effettuato su campione LxH
4x3.2mt Schema A

**Soluzione con rinforzo
centrale per altezza
superiore 2.5mt**

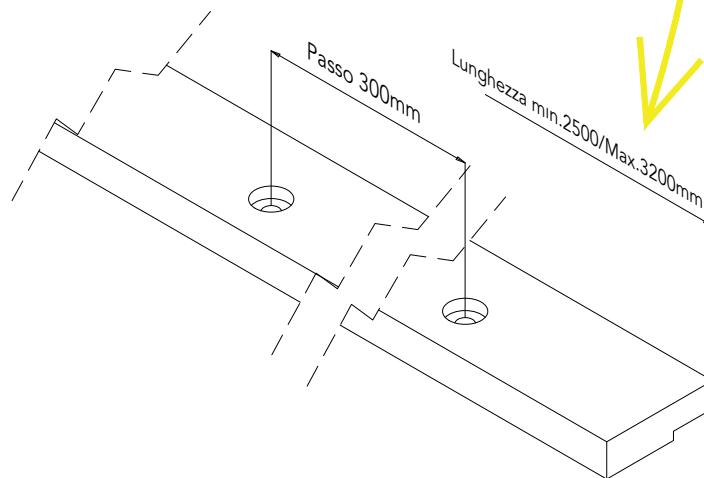

uni_one90° HS magis40

uniform

Zoom 70%

- (IT) Sezione orizzontale serramento alzante scorrevole
- (DE) Horizontalschnitt Hebe-Schiebe-Tür
- (ES) Sección horizontal corredera elevadora
- (FR) Coupe horizontale fenêtre levante-coulissante
- (UK) Horizontal section of sliding window-door

Giunzione della soglia per lunghezze superiori a 6mt

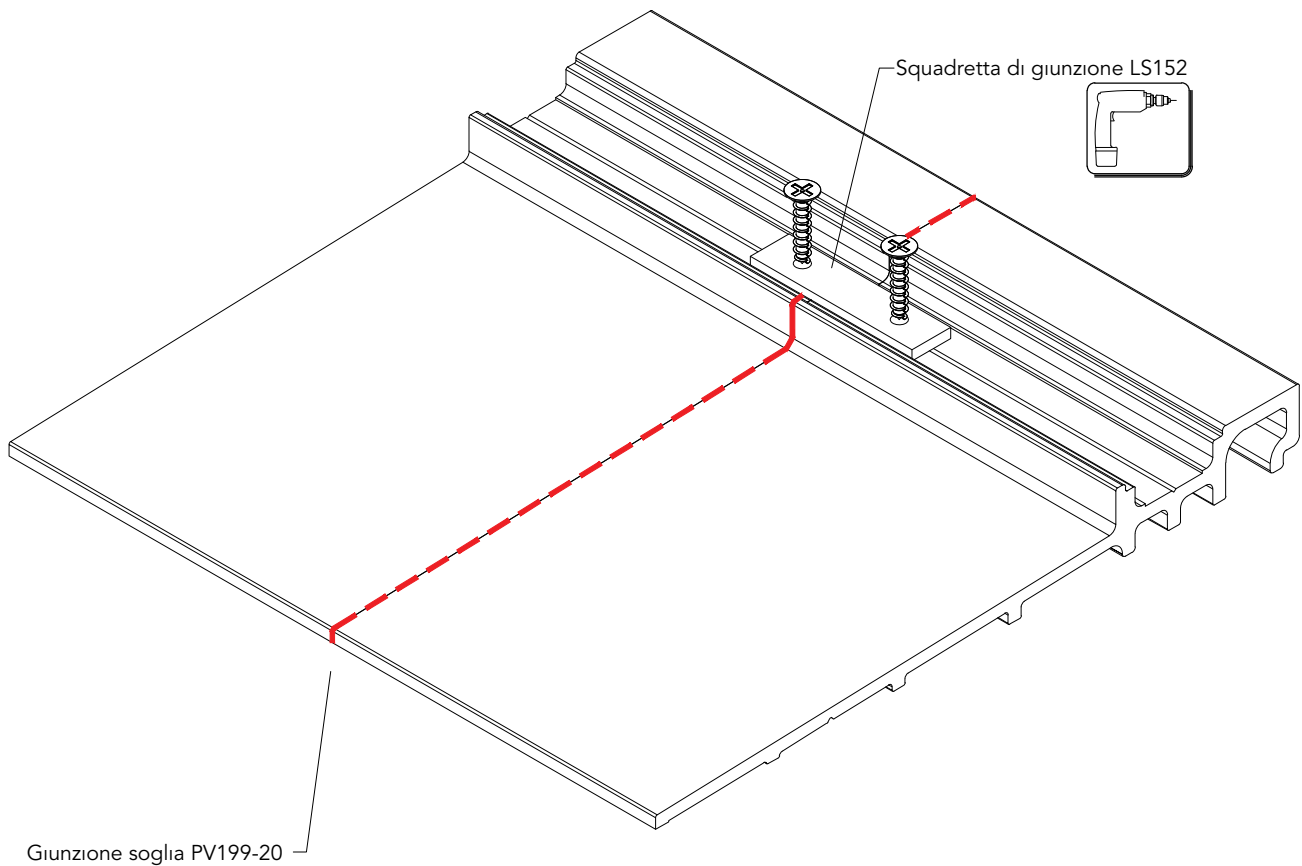

Schema G

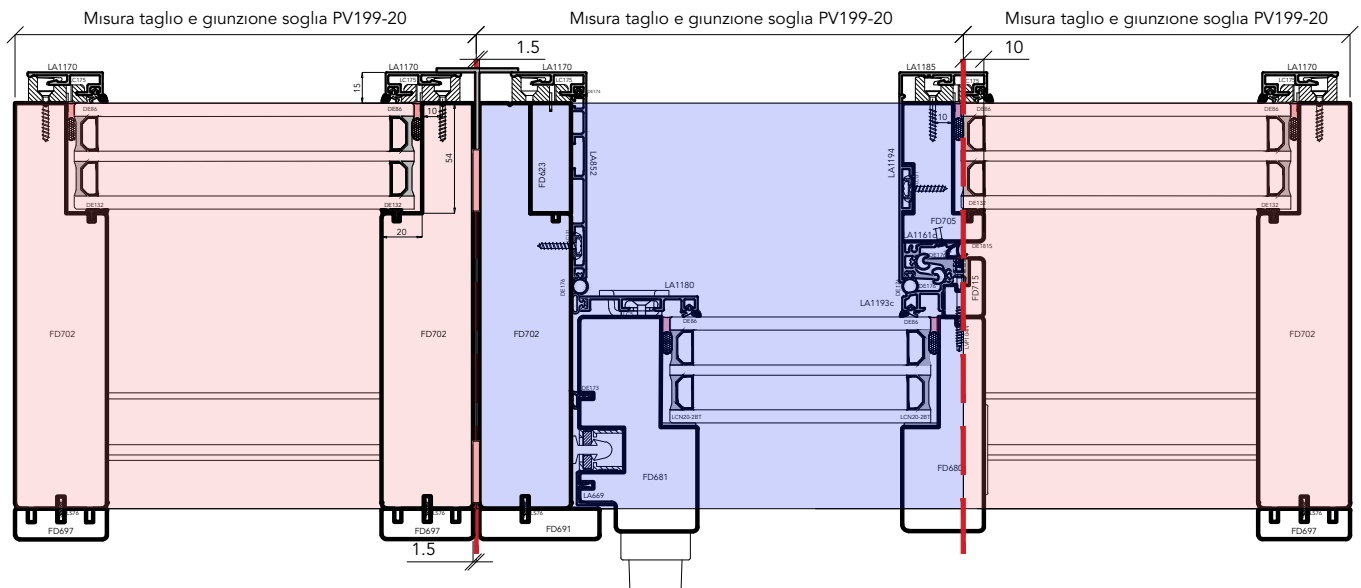
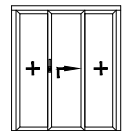

uni_one90° HS magis40

uniform

Scala -

IT	-
DE	-
ES	-
FR	-
UK	-

Giunzione della soglia per lunghezze superiori a 6mt

Schema K

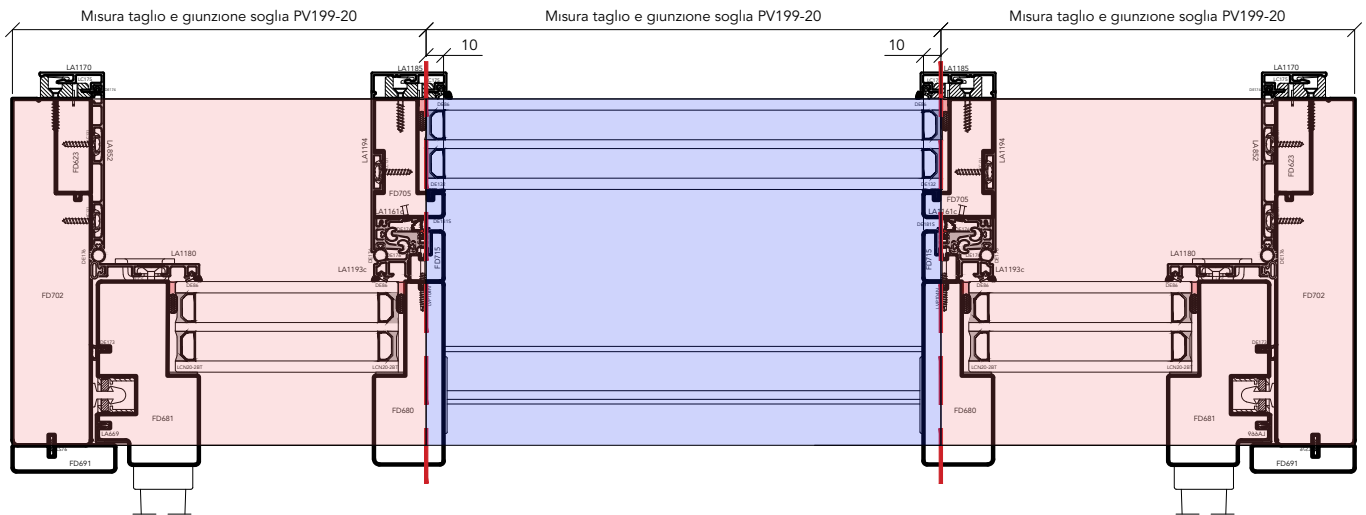
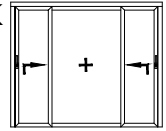

Schema F

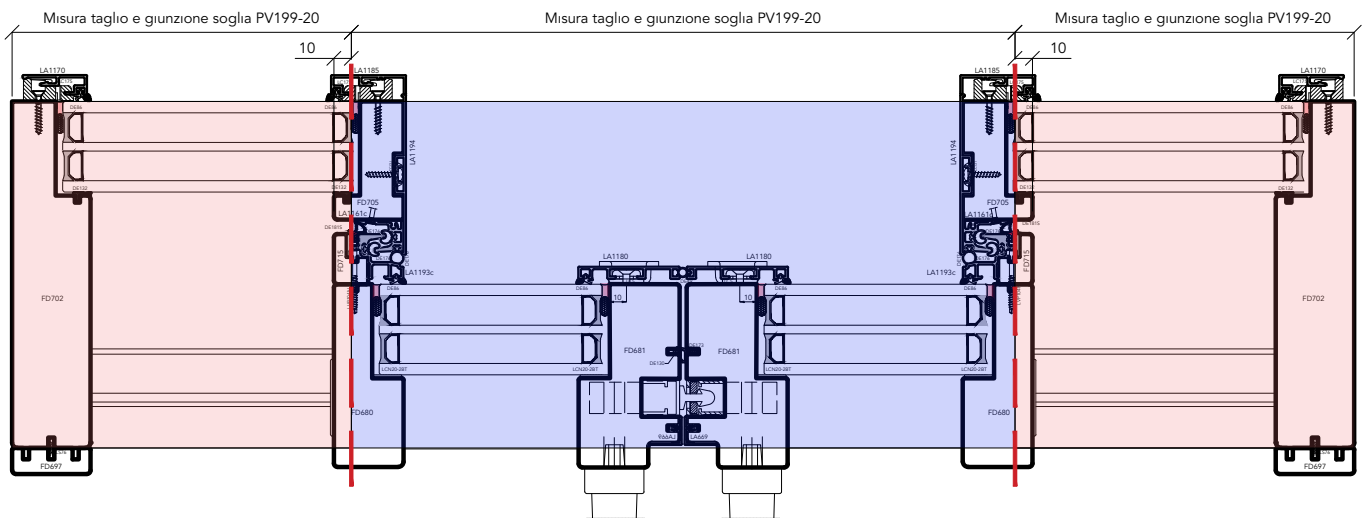
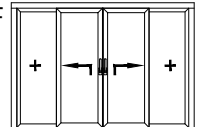

uni_one90° HS magis40

uniform

Scala -

- IT -
- DE -
- ES -
- FR -
- UK -

Prospetto vista interna
Internal view

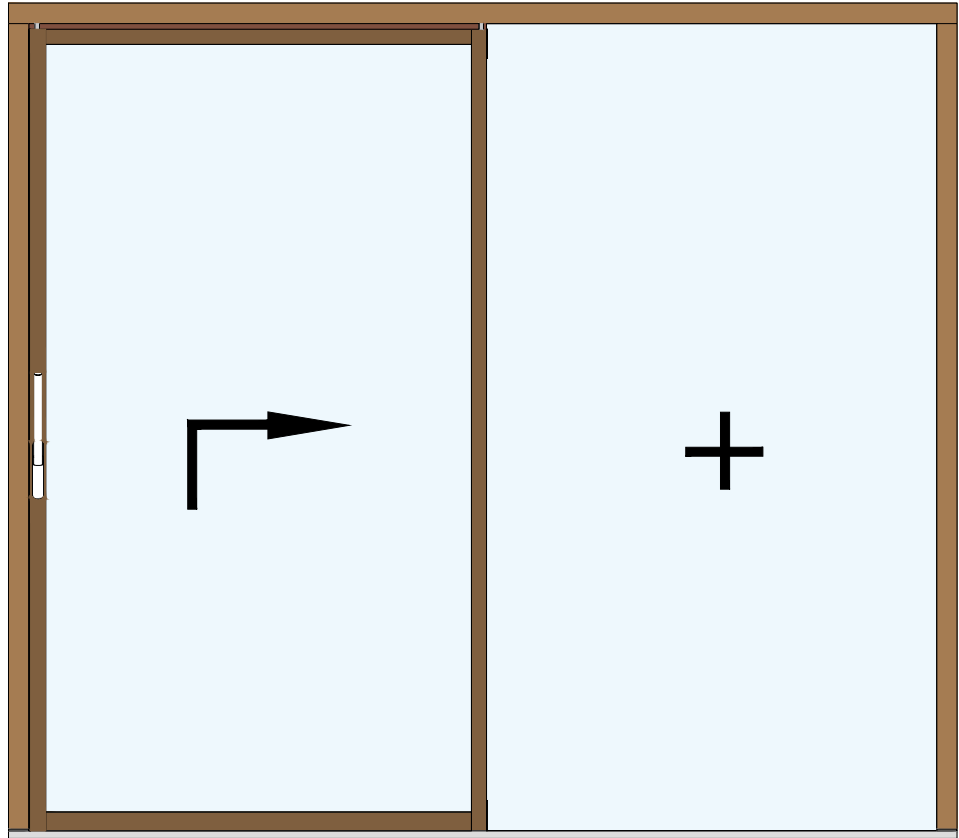

Prospetto vista esterna
External view

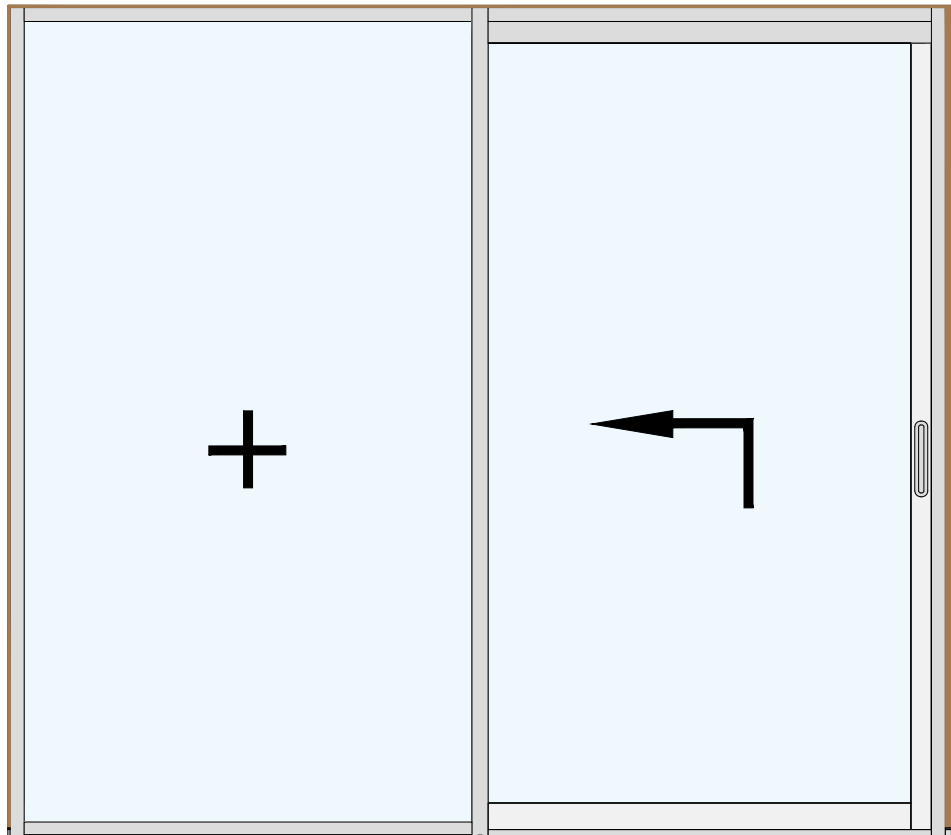

uni_one90° HS magis40

uniform 

Scala 1:20

- IT
- DE
- ES
- FR
- UK

Istruzioni per l'assemblaggio
Assembly instructions



ISTRUZIONI PER IL MONTAGGIO HS-MAGIS40

Procedura e passaggi consigliati per la costruzione ed installazione:

Lavorazioni sul telaio:

1. Taglio soglia PV199-20
2. Montaggio LC131 sulla soglia
3. Montaggio terminali laterali PT199-20
4. Montaggio terminale centrale PT199-40A
5. Montaggio binario a scatto LA1167
6. Montaggio clips LC251
7. Montaggio profilo LA1197 o LA1195
8. Montaggio LP214 o LP217 sulla soglia
9. Foratura dei montanti telaio con dima LD72
10. Foratura del traverso superiore con dima LD72
11. Foratura del traverso superiore con dima LD73
12. Foratura ed intestatura del piantone centrale FD700 o FD705
13. Montaggio guida superiore LA1162c e LC1162
14. Montaggio terminali superiori laterali kit LC181-40 sulla guida LA1162c
15. Assemblaggio del telaio in legno
16. Montaggio FD701 o FD706
17. Montaggio clips LC175 sul telaio
18. Montaggio LC131 sulle spalle laterali
19. Montaggio accessorio LC192
20. Montaggio LA1161c su piantone
21. Montaggio dei profili alluminio sul telaio

Lavorazioni sull'anta:

22. Assemblaggio dell'anta in legno
23. Montaggio U20x10
24. Montaggio clips LC5
25. Montaggio della cremonese, carrelli e fermo LS148
26. Montaggio guarnizione DE173-E lato esterno e LA669 sul lato interno
27. Rimozione del liner sul biadesivo strutturale anta
28. Montaggio vetro e sigillatura esterna
29. Spessoramento vetro e verifica dimensioni
30. Montaggio profilo FD715 su anta in legno
31. Montaggio telaio in alluminio sull'anta
Fissaggio LA1193c su anta in legno
Montaggio DE181-S e DE176
Sigillatura e montaggio terminale LC197
32. Chiusura delle clips LC5 per bloccaggio telaio in alluminio
33. Montaggio LA1134
34. Montaggio LS145 e maniglione

Installazione:

35. Posizionare il telaio, mettere in bolla, spessorare e fissare alla struttura portante
36. Girare le clips LC175 nel lato vetro fisso
37. Inserire il vetro fisso
38. Sigillare il vetro fisso nella parte perimetrale esterna
39. Girare LC175 per il bloccaggio del vetro
40. Inserire i profili a scatto LA1170, LA1175 e LA1185 già con guarnizione DE86 premontata
41. Inserire l'anta (posizione carrello chiuso) e bloccare l'anta con i terminali superiori (vedi kit LC195).
Avvitare le calamite nel lato inferiore e superiore ed applicare le coperture in acciaio lucido LC196.
Montaggio del paracolpi a scomparsa su guida superiore LA1162c.
42. Montare i rostri di chiusura sul telaio
43. Verificare scorrimento e corretta chiusura dell'anta
44. Sigillare e montare eventuali coprifili interni

Guarda il video istruzioni di
montaggio uni_one HS-magis40:

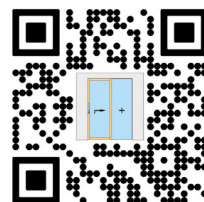

1
2

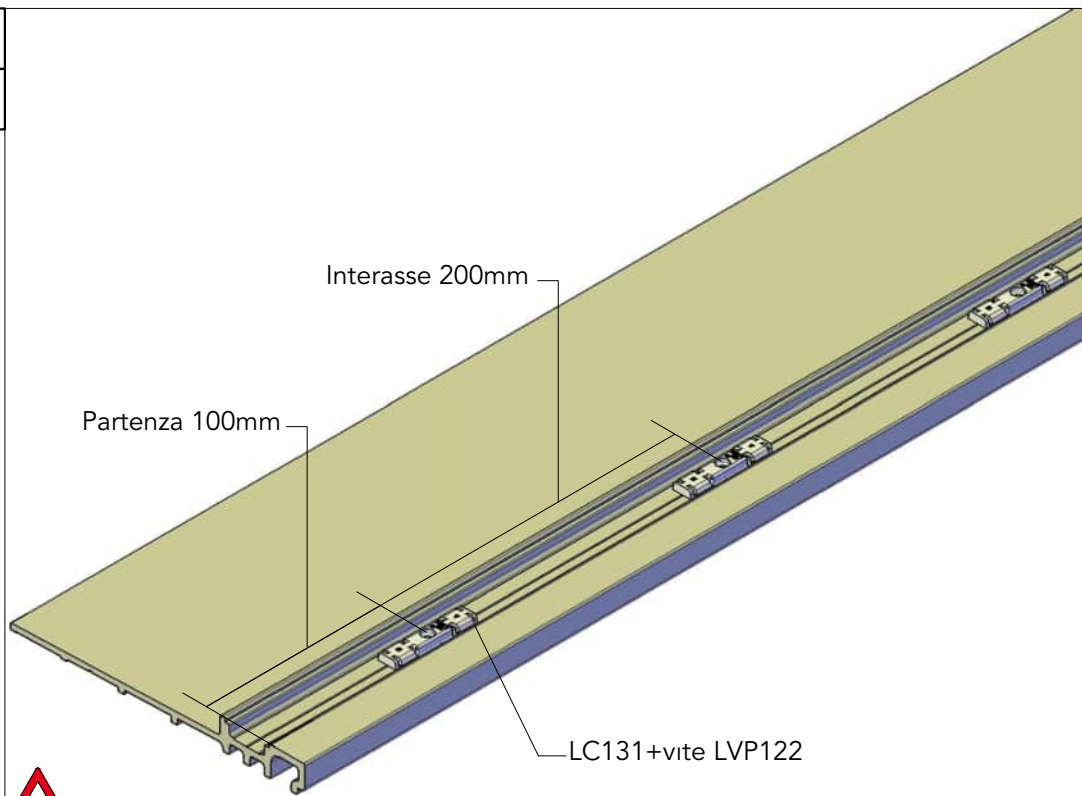

Per il taglio del profilo soglia utilizzare lama diamantata Ø450mm

3

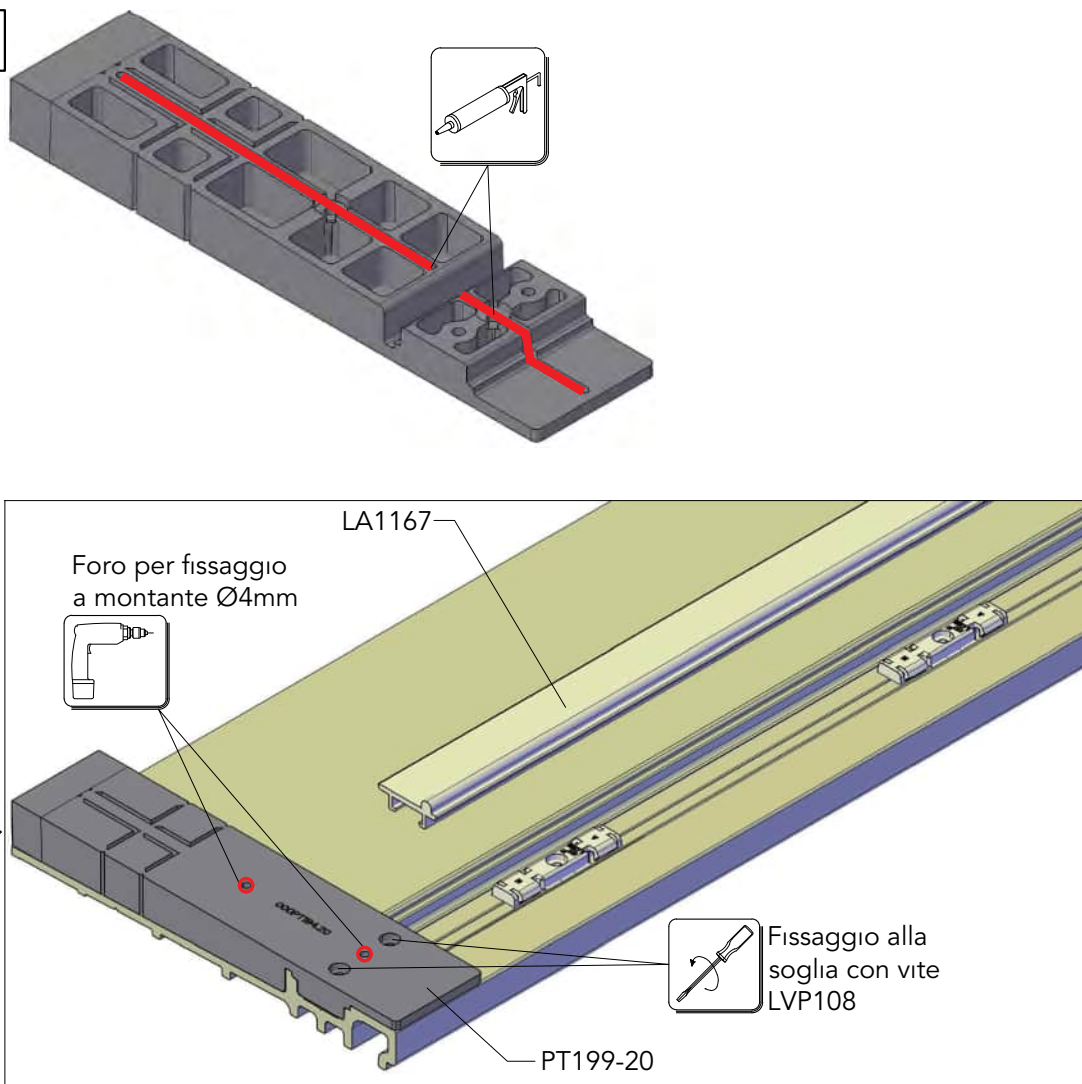

4

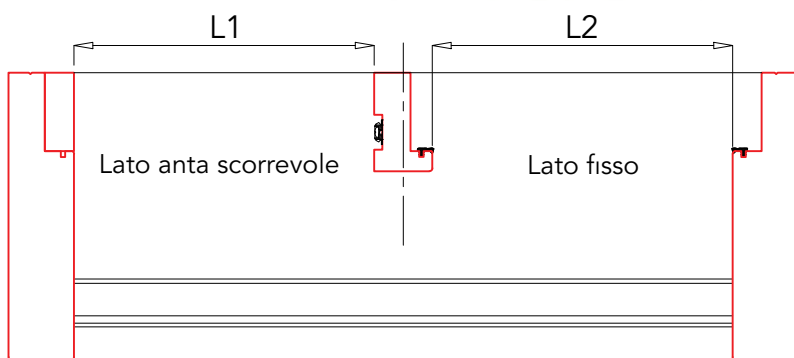
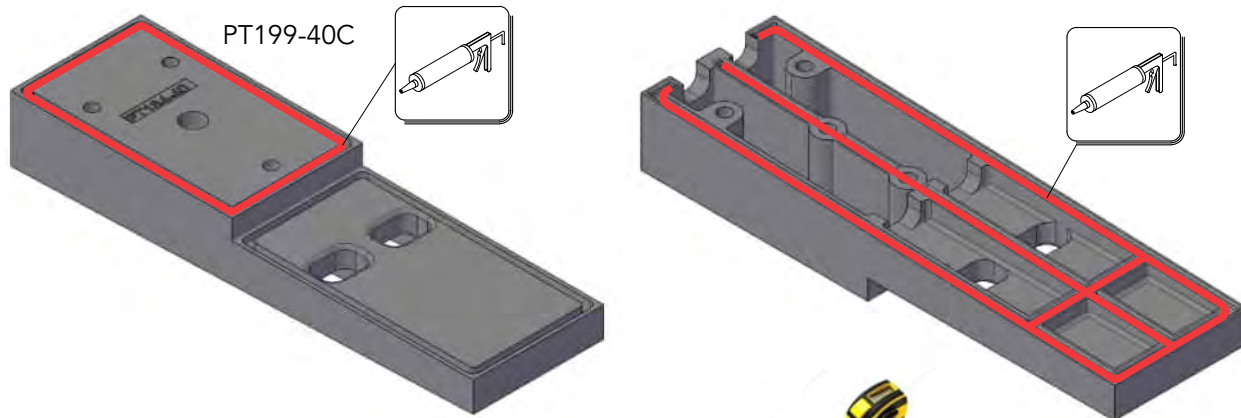

Segnare le misure di posizionamento sulla soglia utilizzando come riferimento il terminale centrale

Fissare il terminale centrale a misura. Utilizzare il terminale come dima per la foratura della soglia

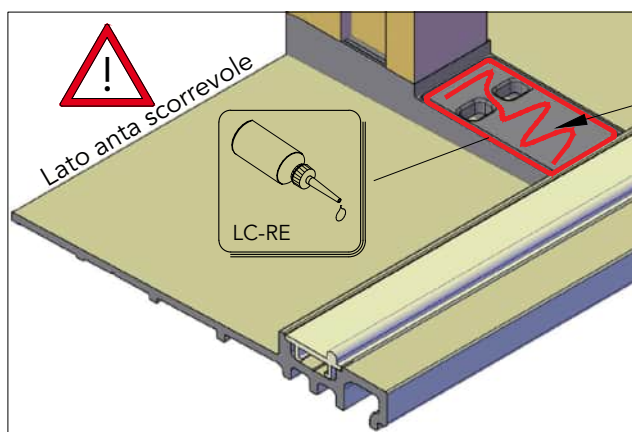
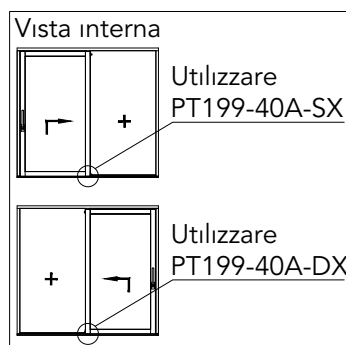
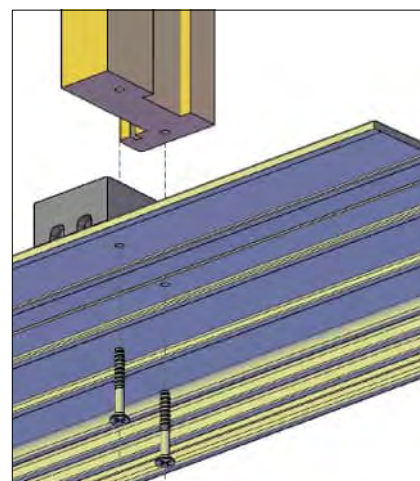
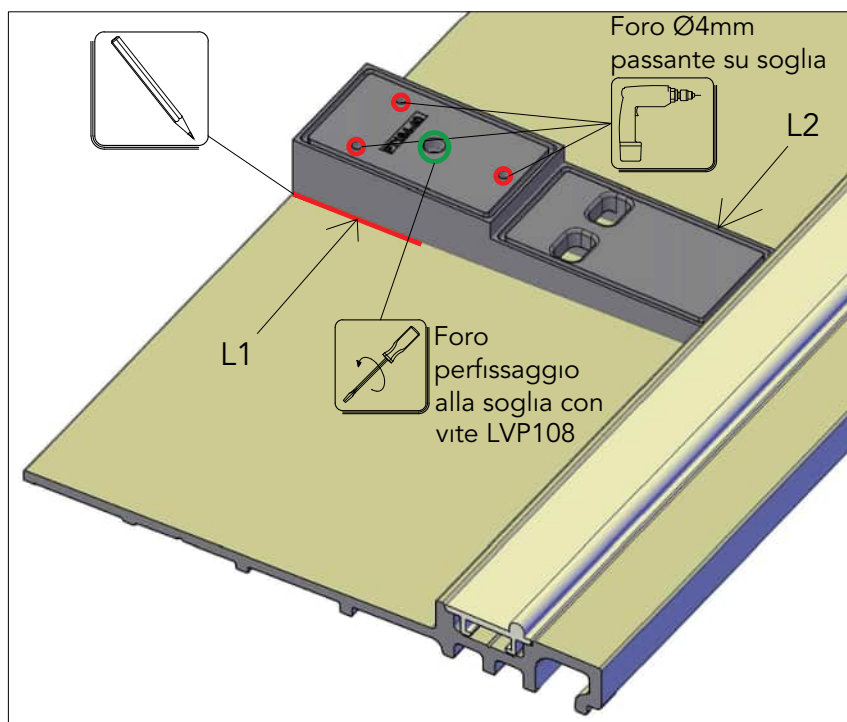

Incollare abbondantemente ed inserire il terminale in EPDM morbido con colla cianoacrilica LC-RE

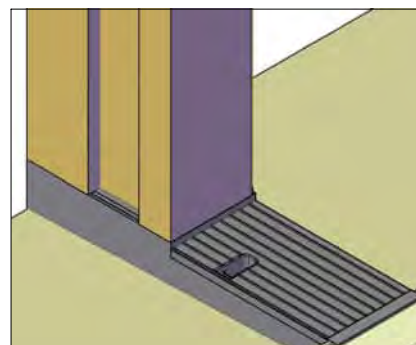

5

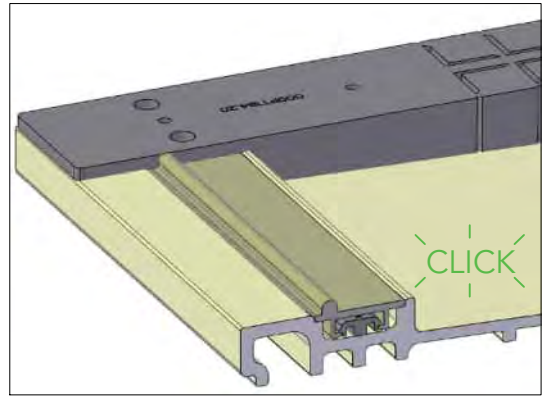
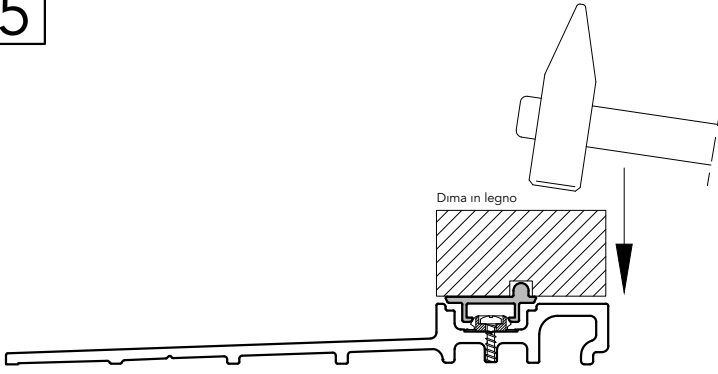

6

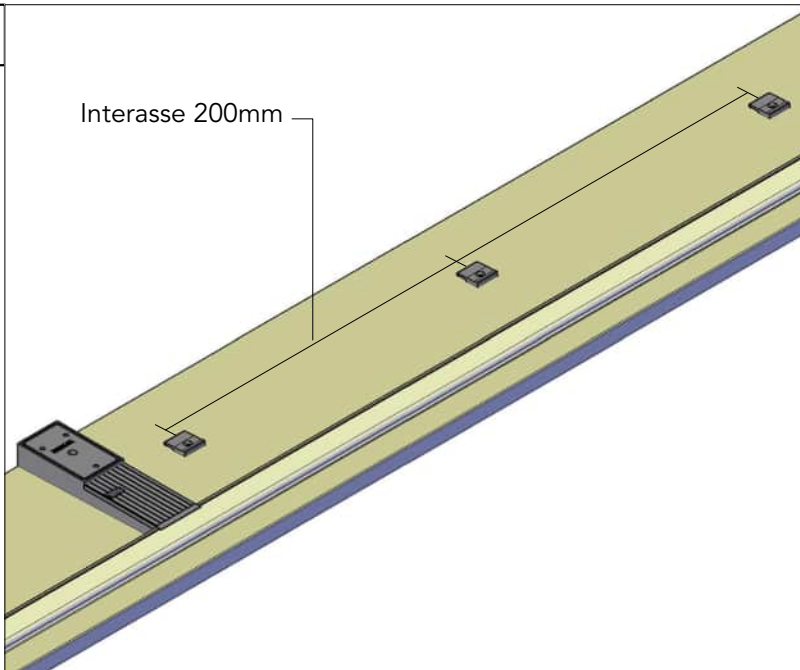

Vite autoformante LVP3x10
(Preforo Ø2.5)

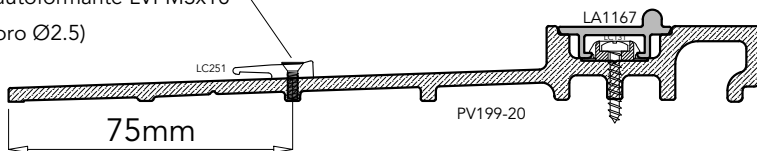

7

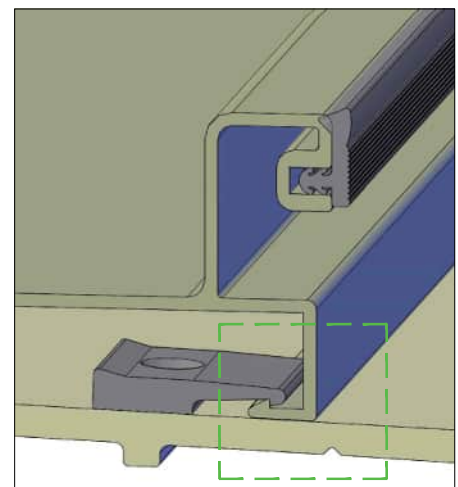
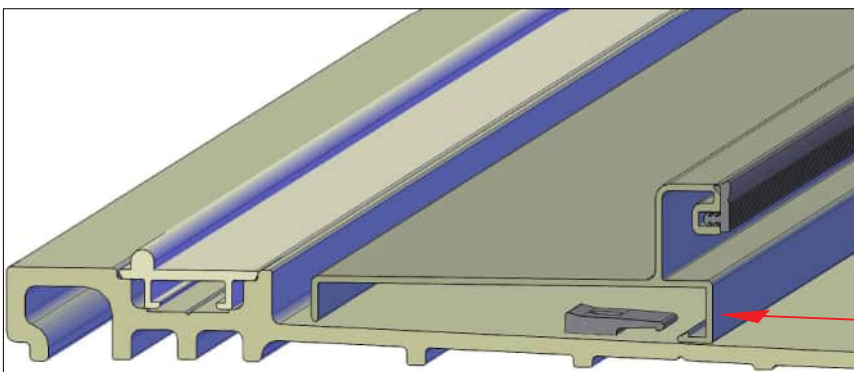

8

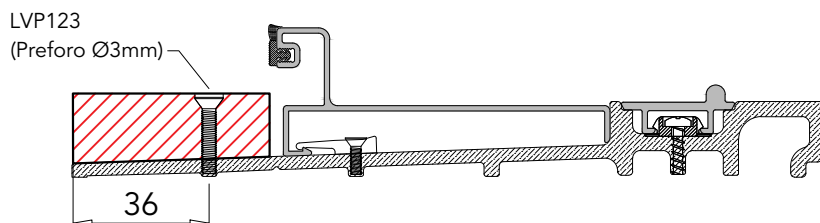
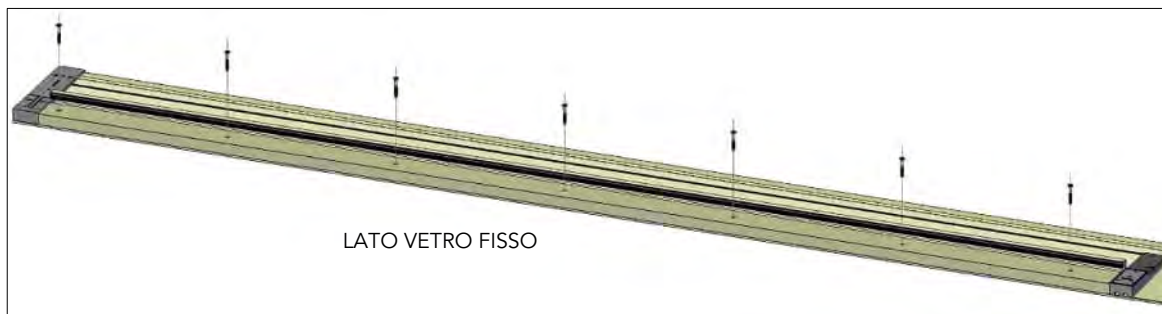

9

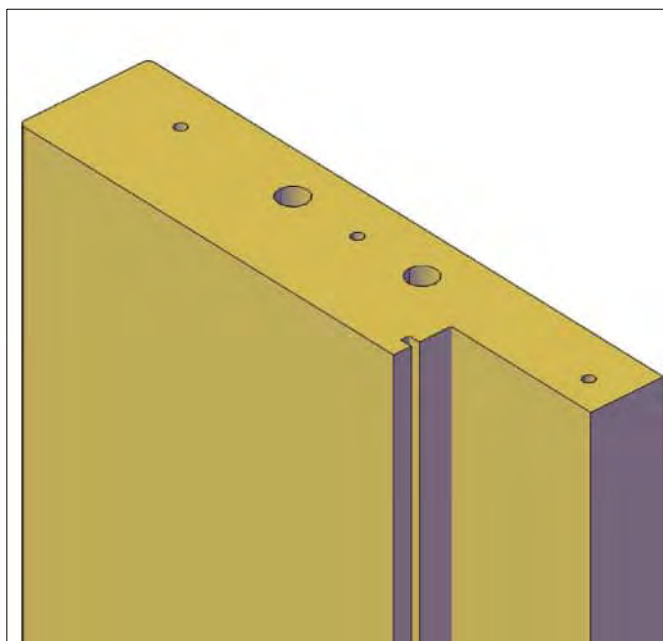
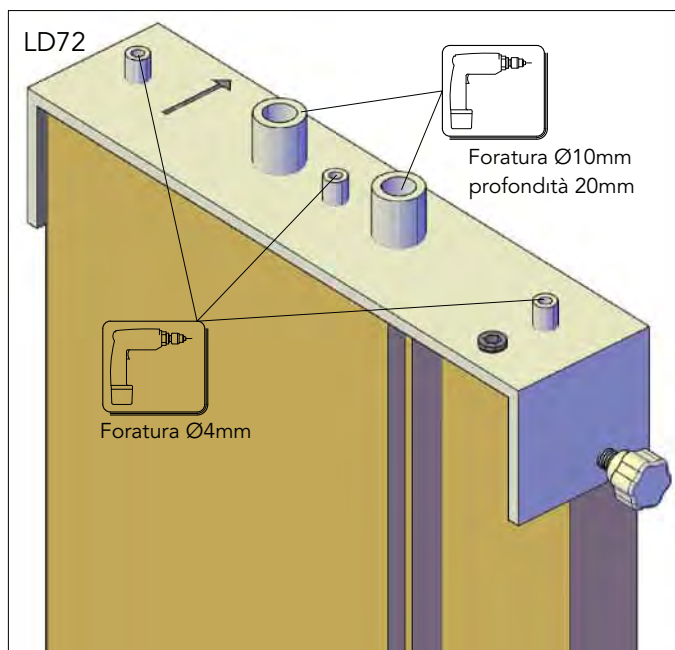

10

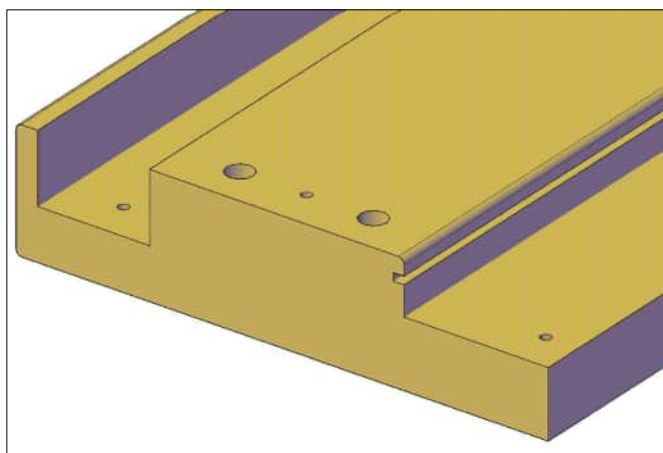
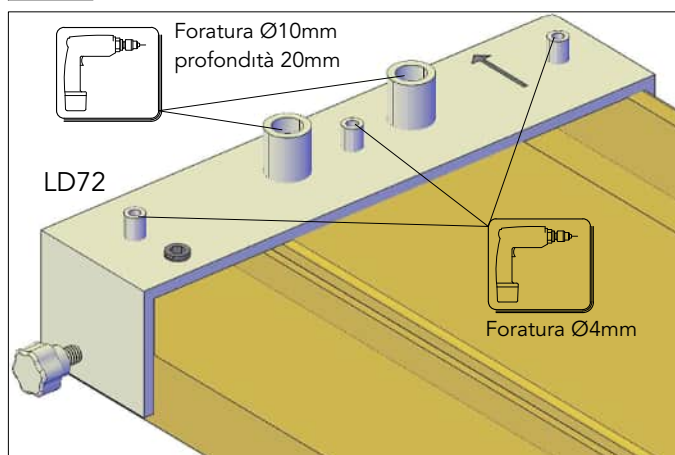

11

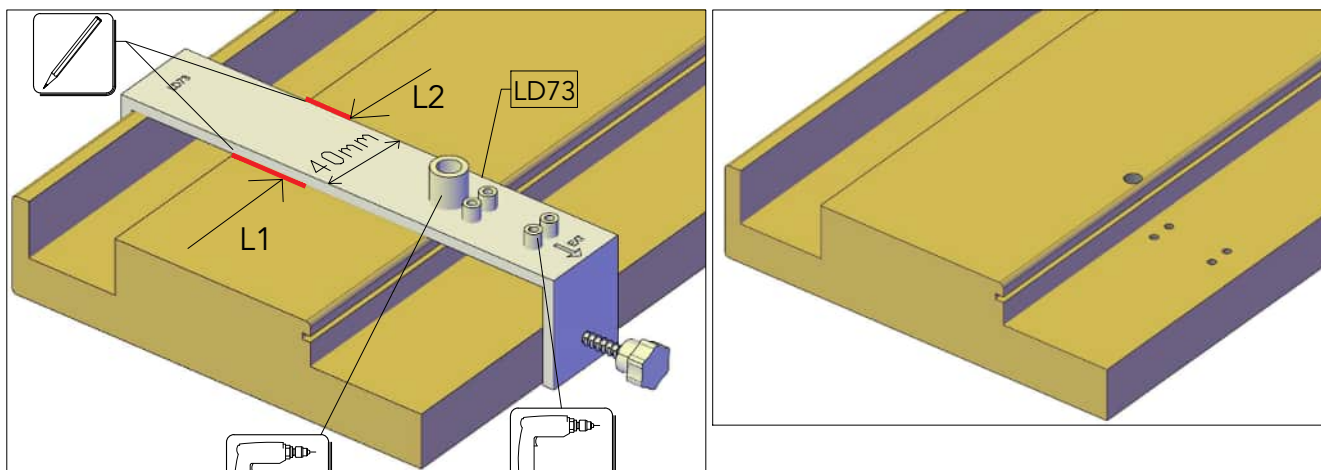

12

Foratura
Ø10mm

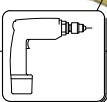

Foratura Ø4mm

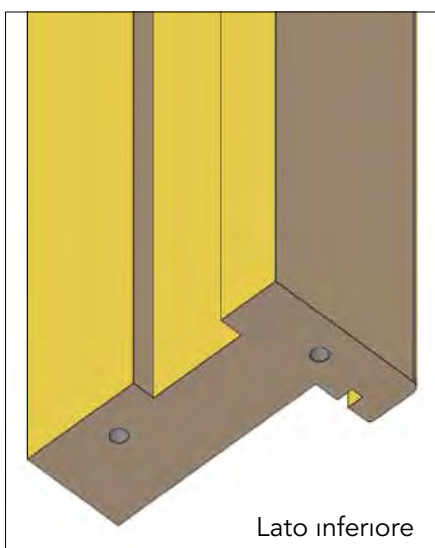
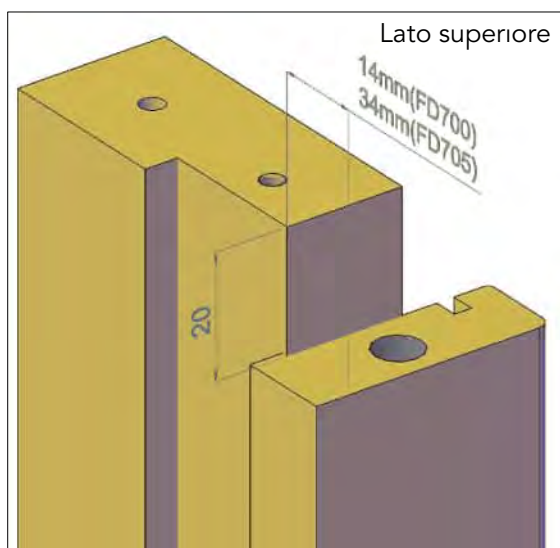

Lavorazioni automatiche
eseguite su CNC STEMA

13

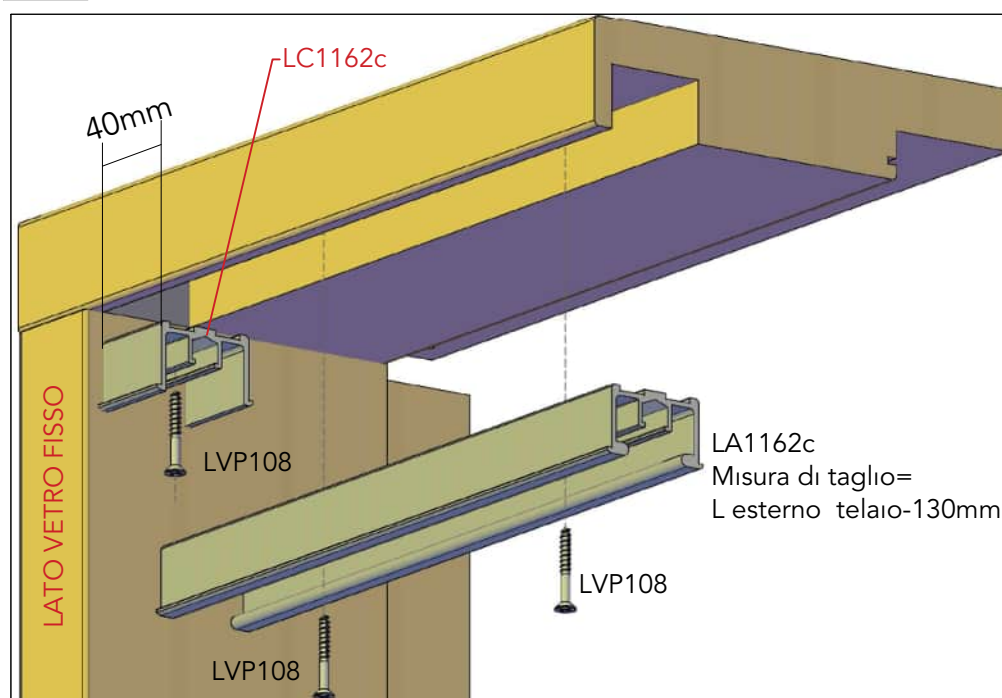

14

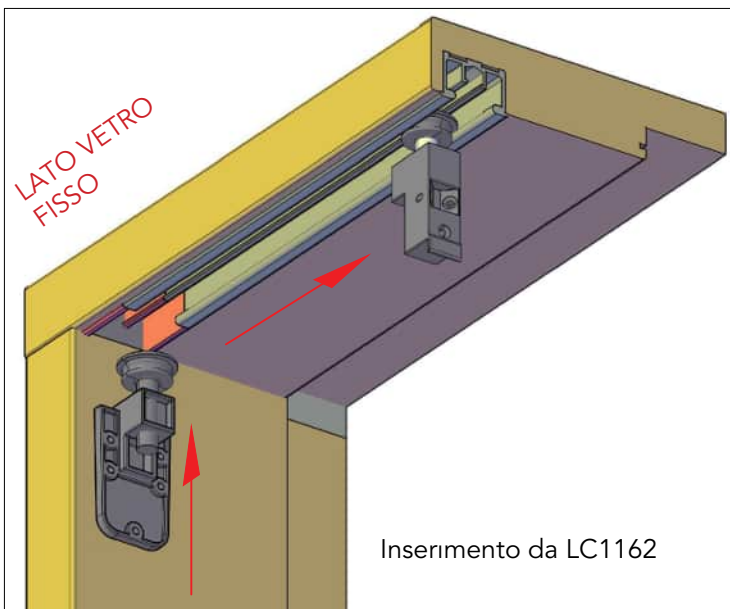

15

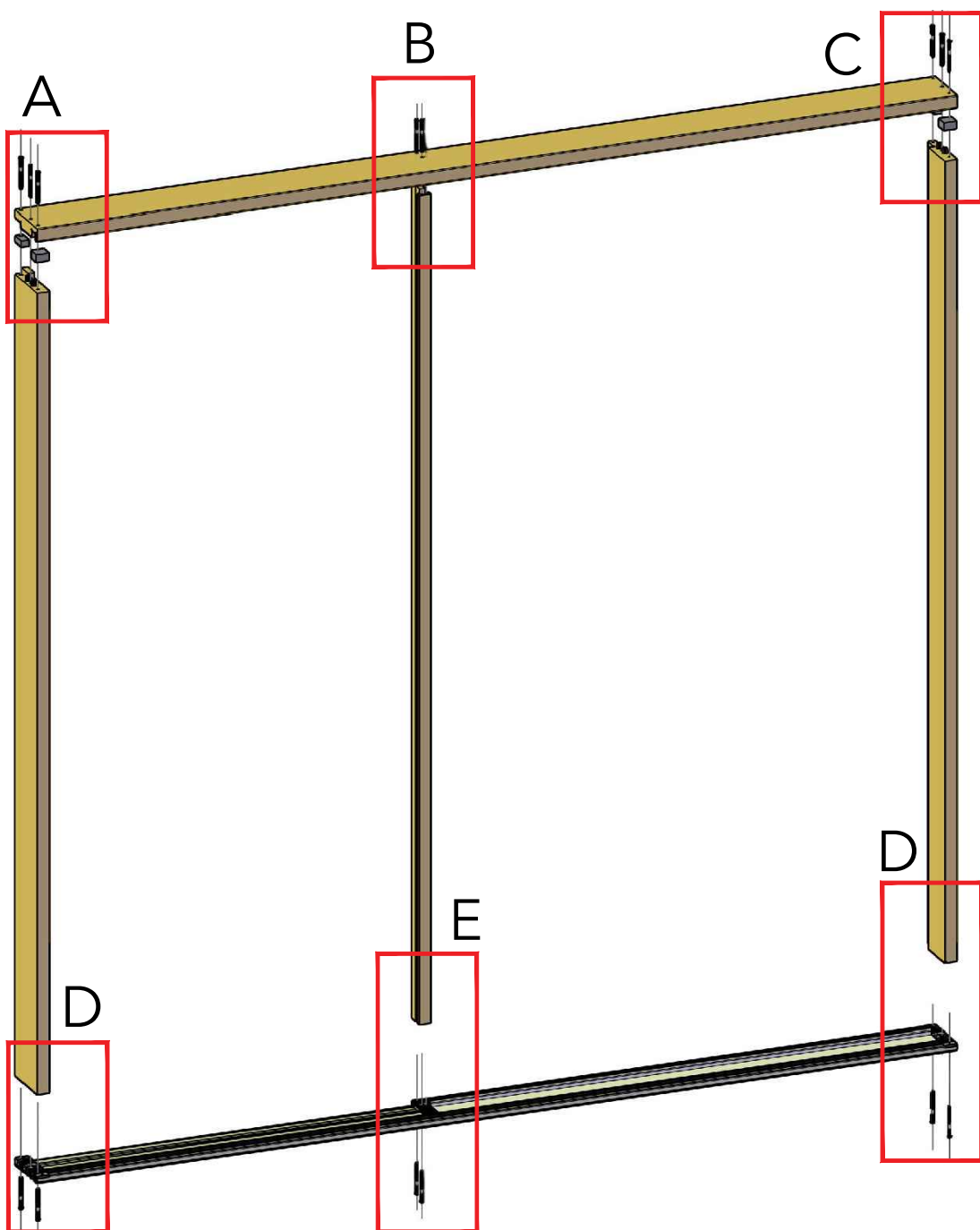

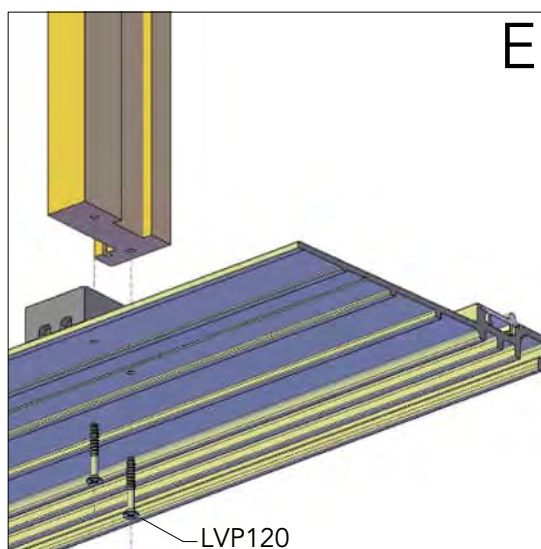
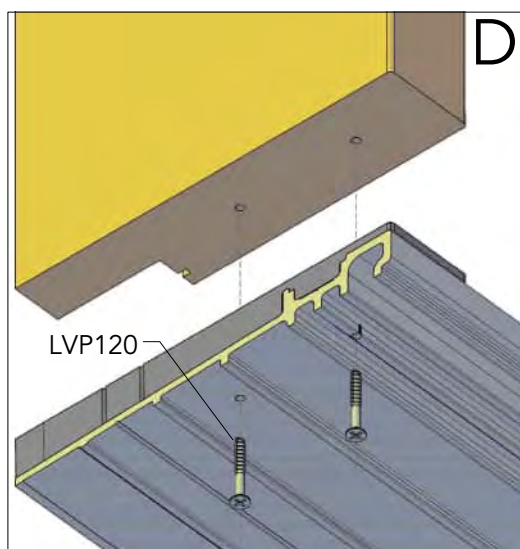
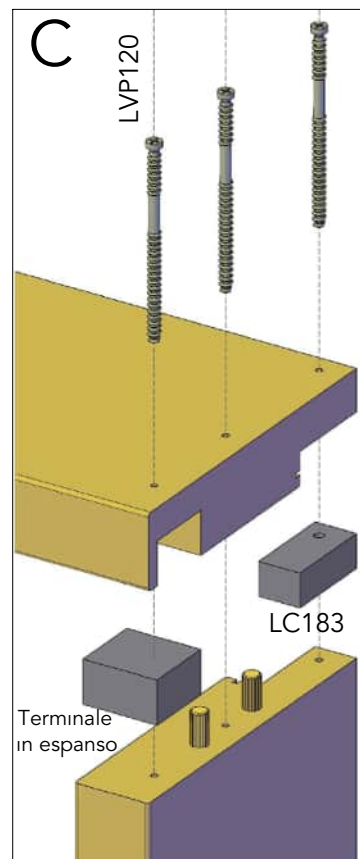
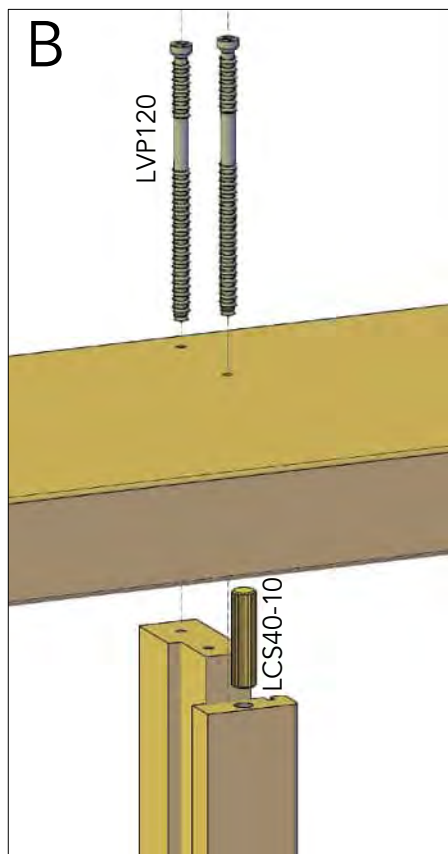
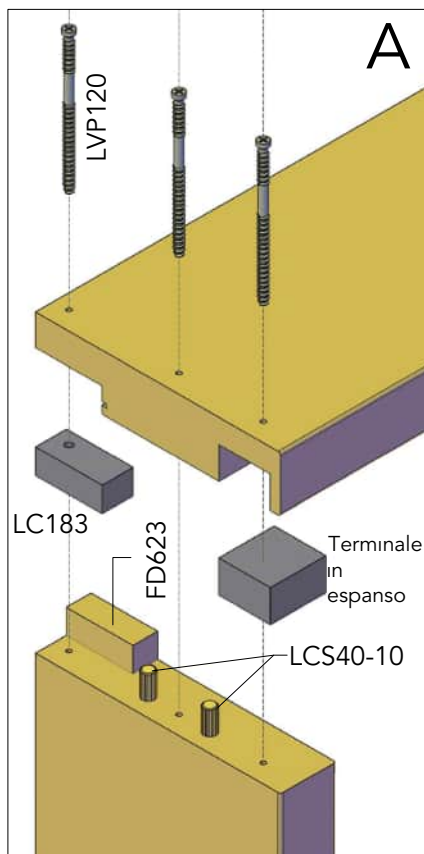

16

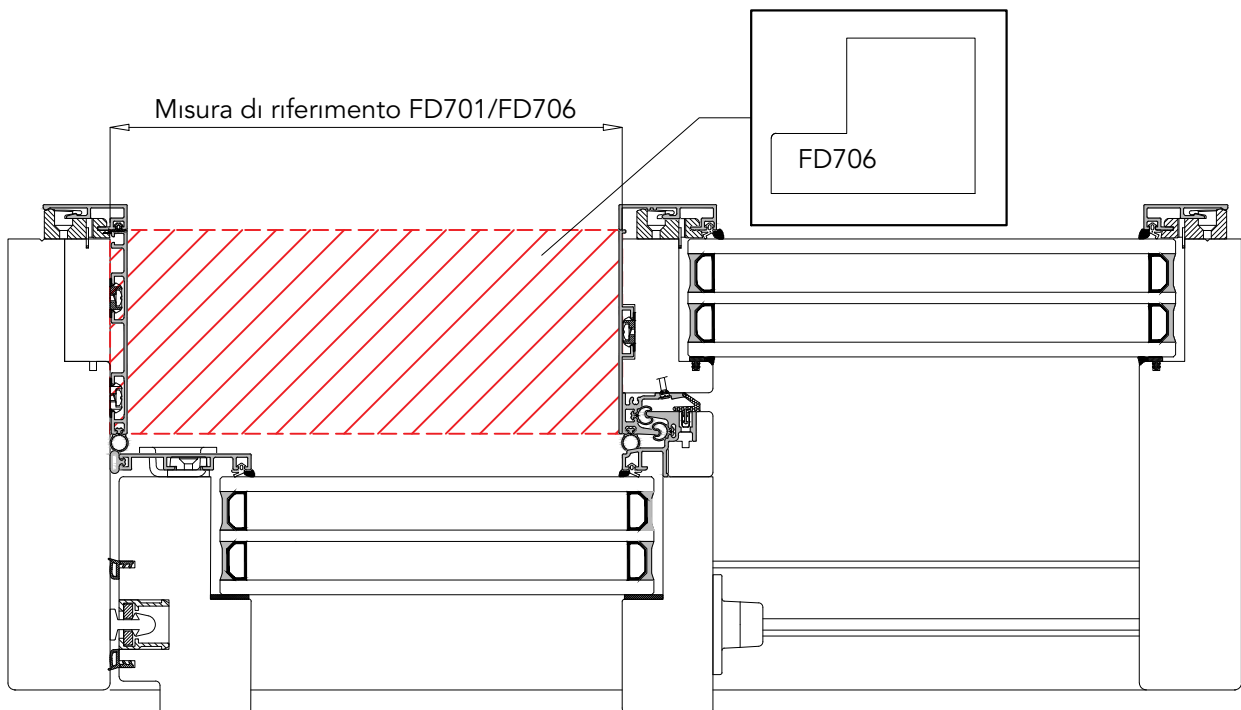
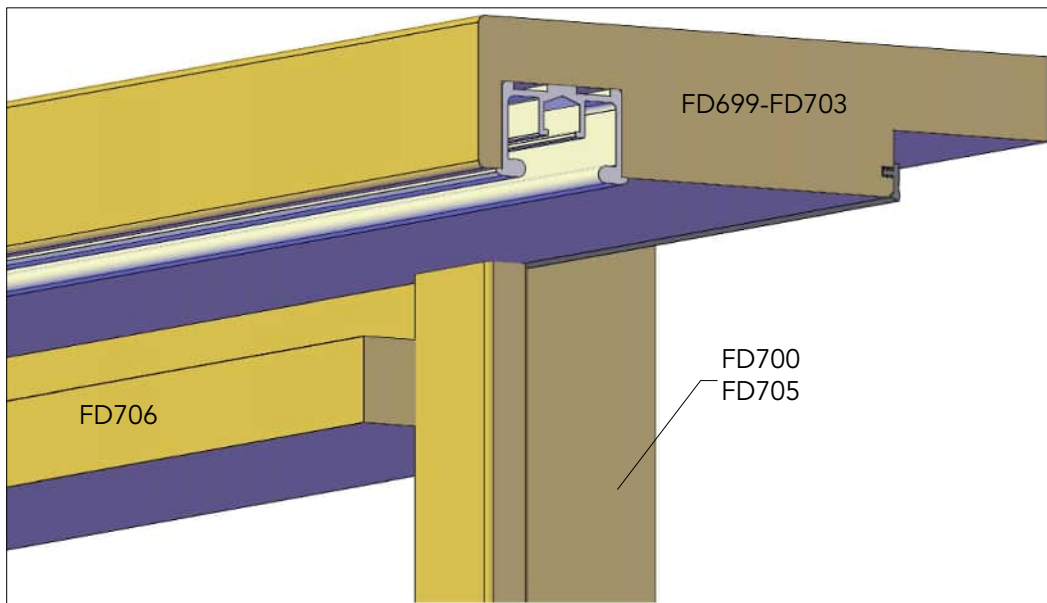
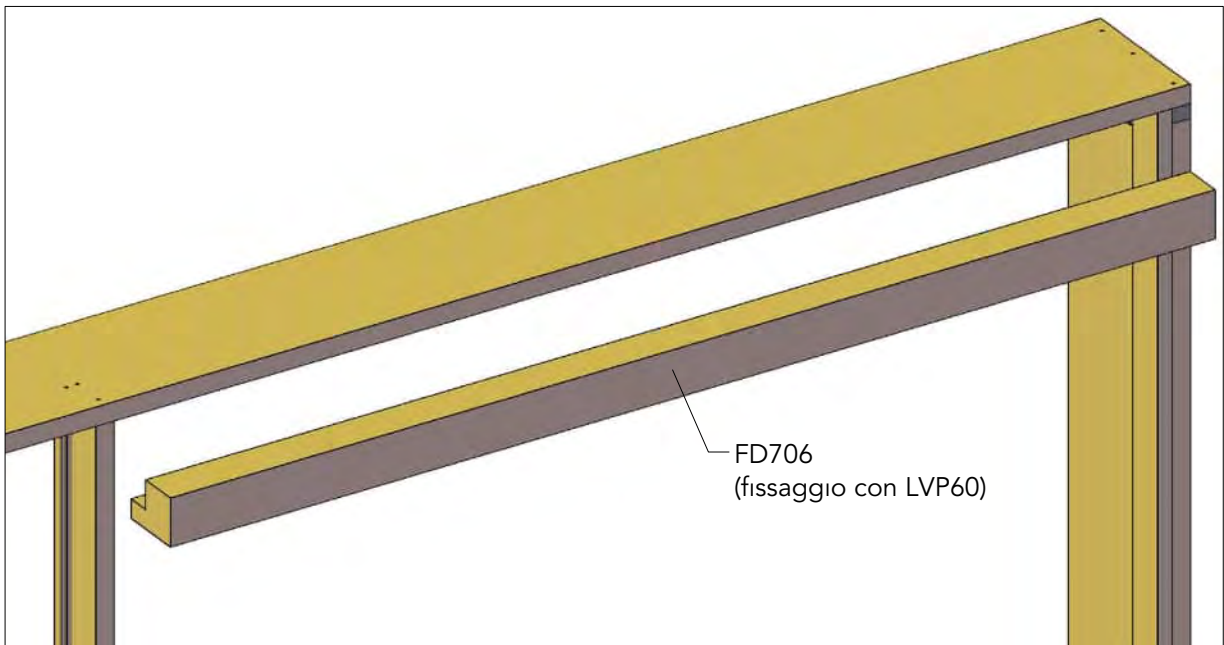

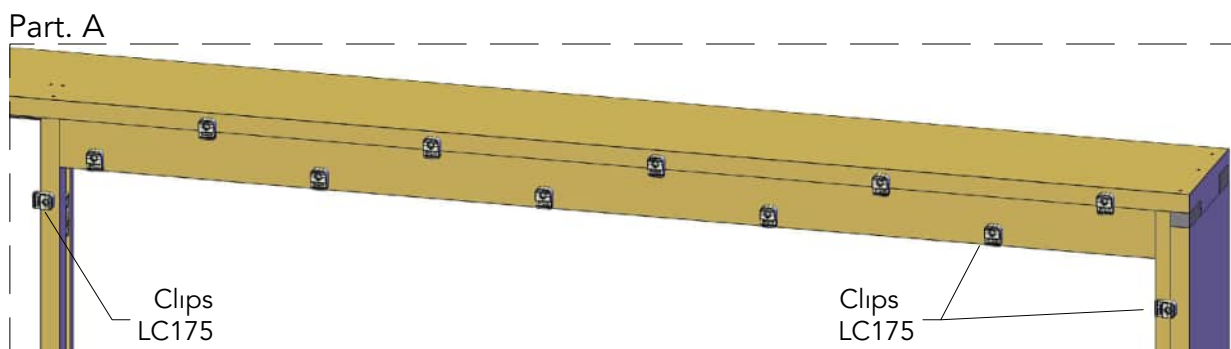

18

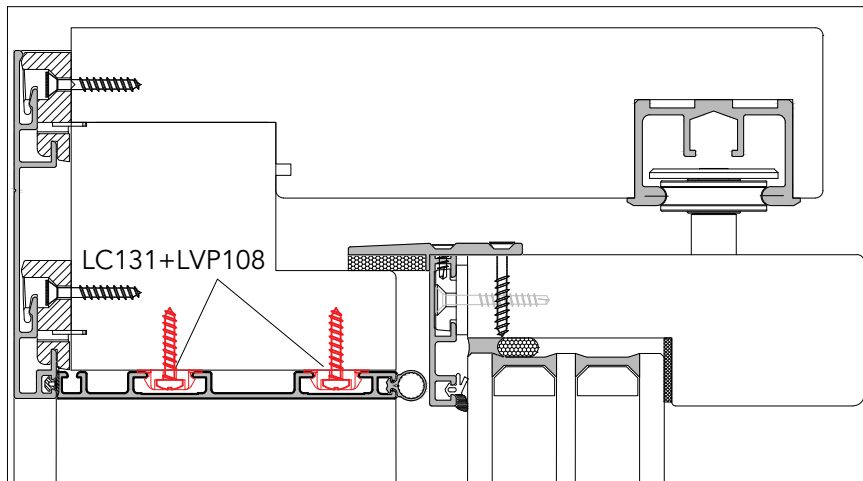
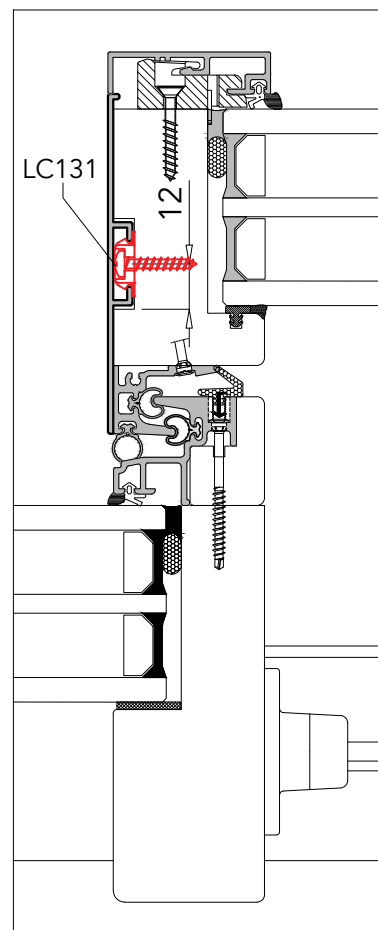
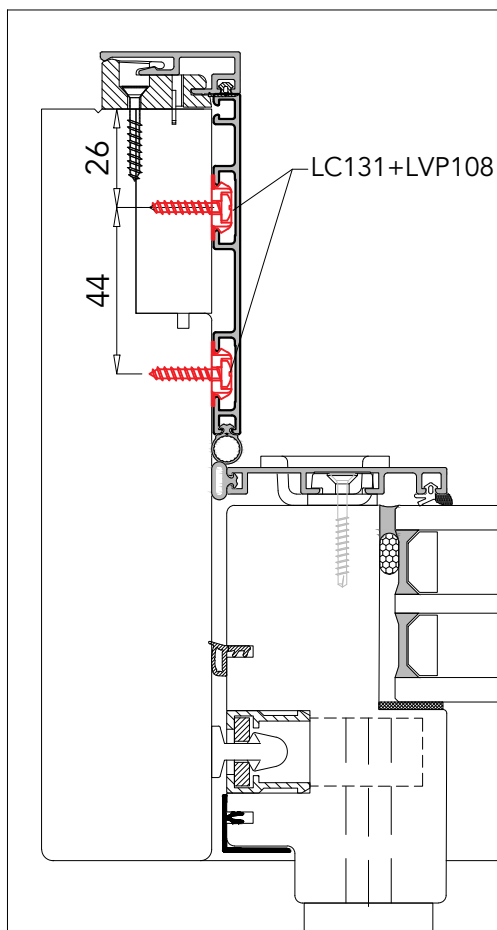
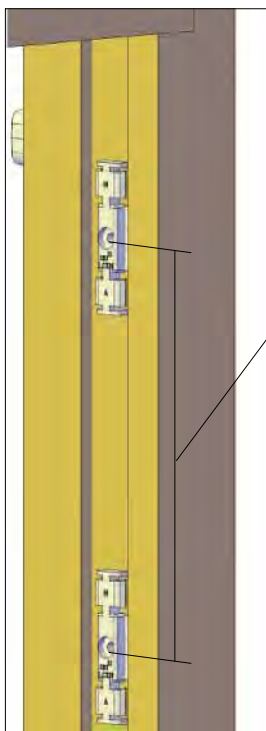
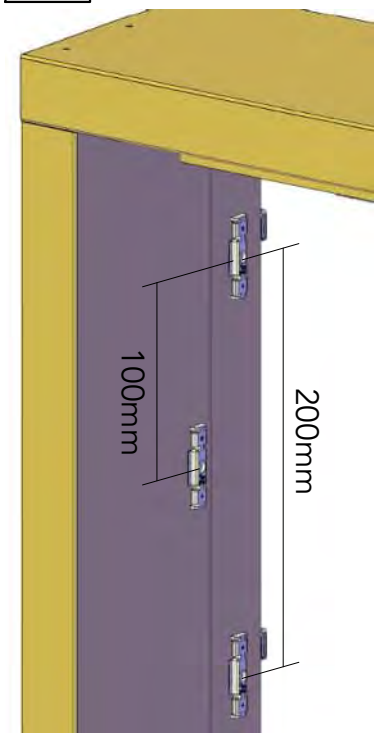

19 Schema A

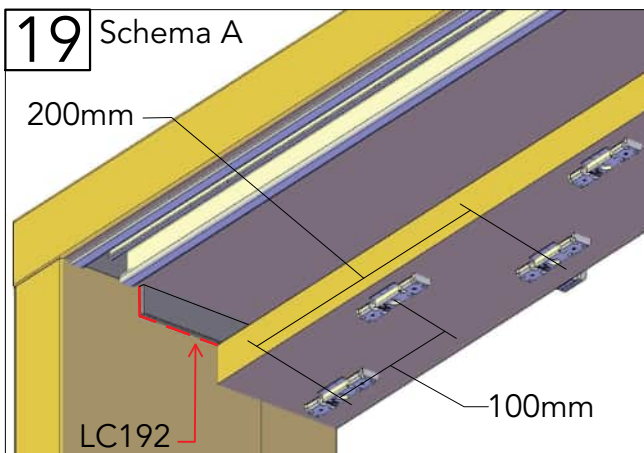

Schema F

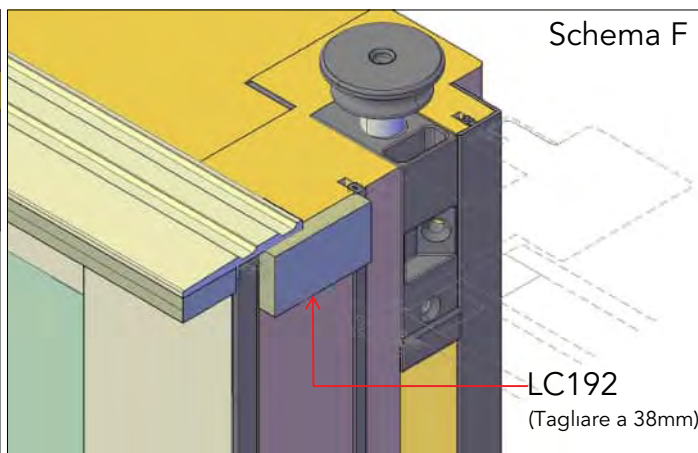

20

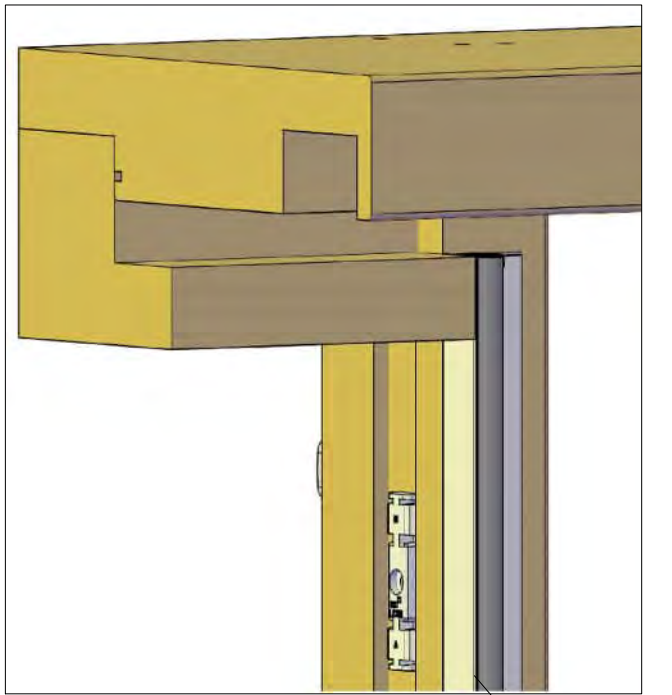

LA1161c

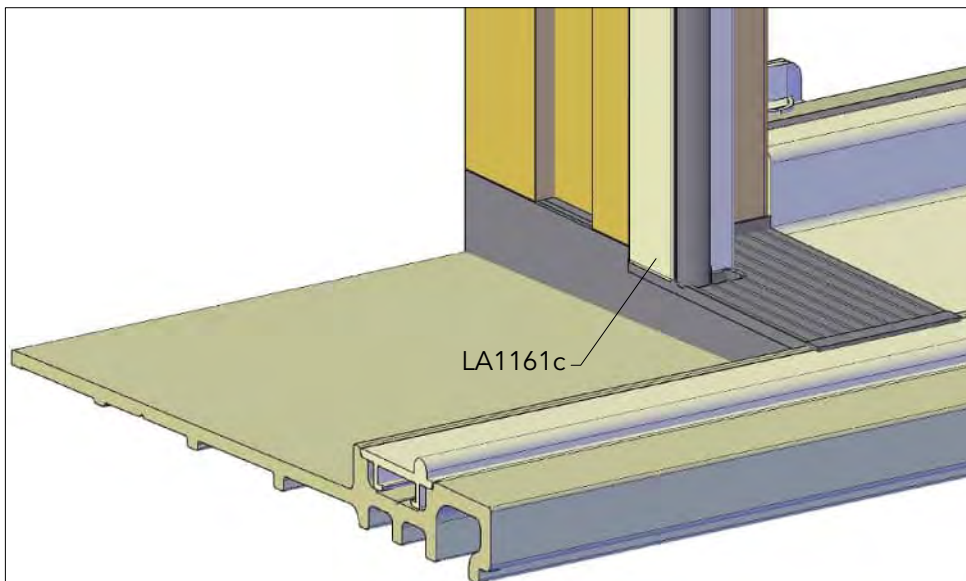
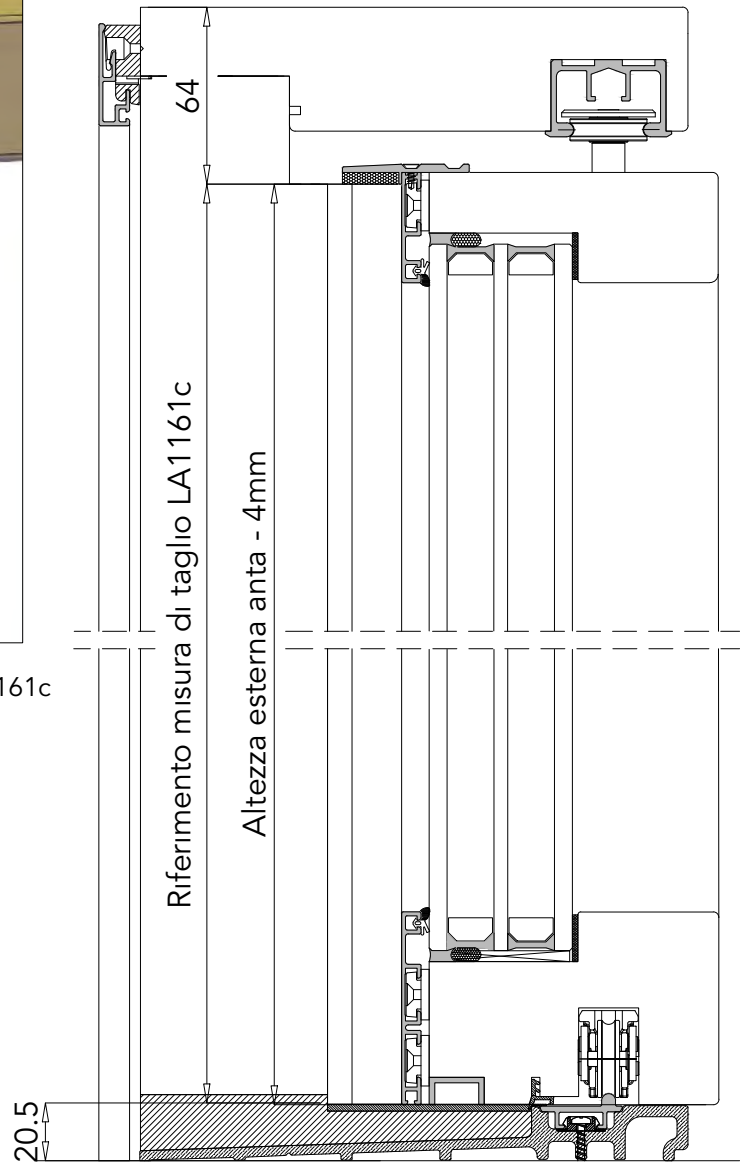

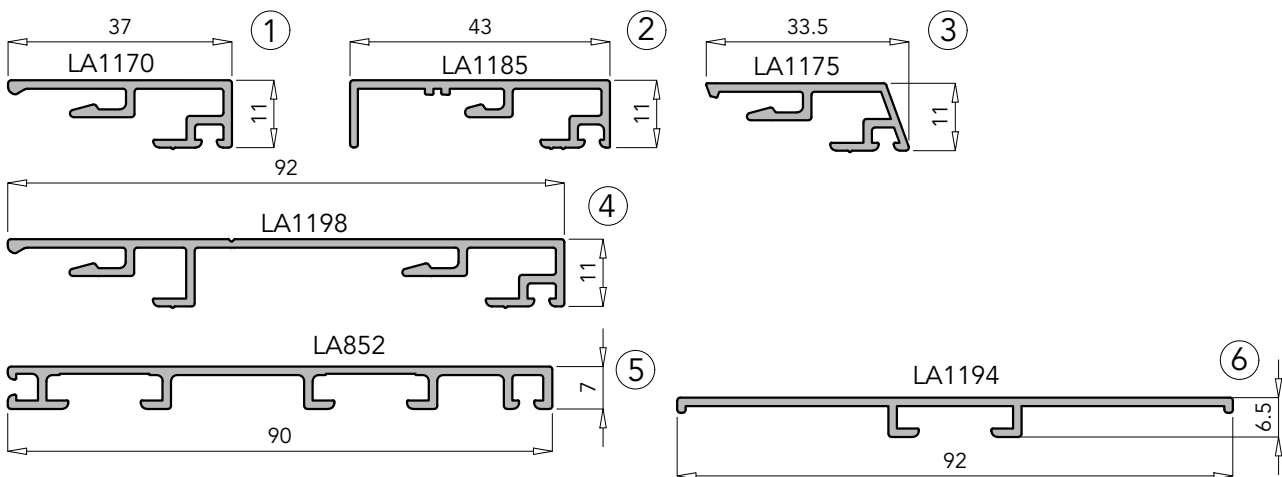
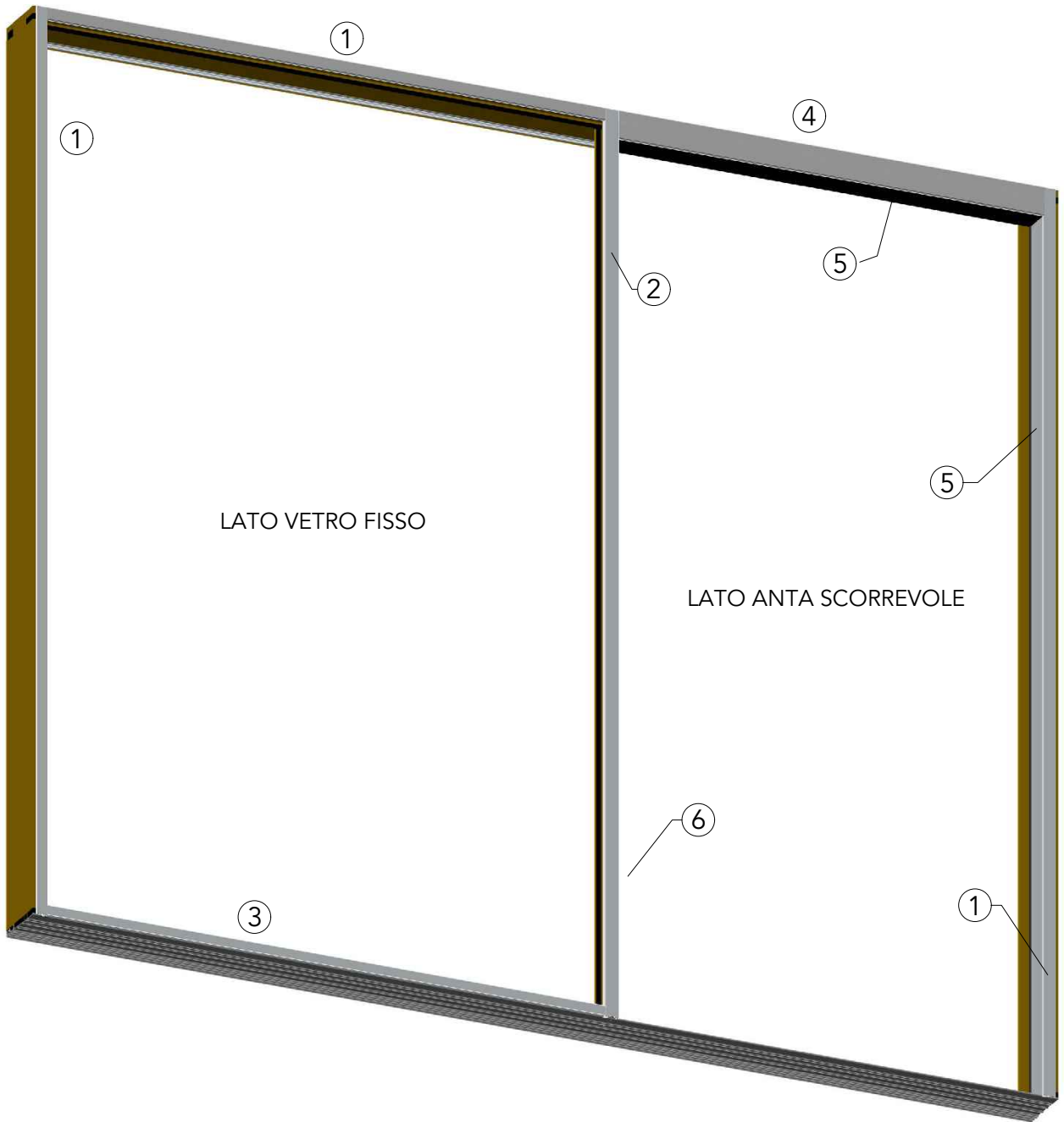

22

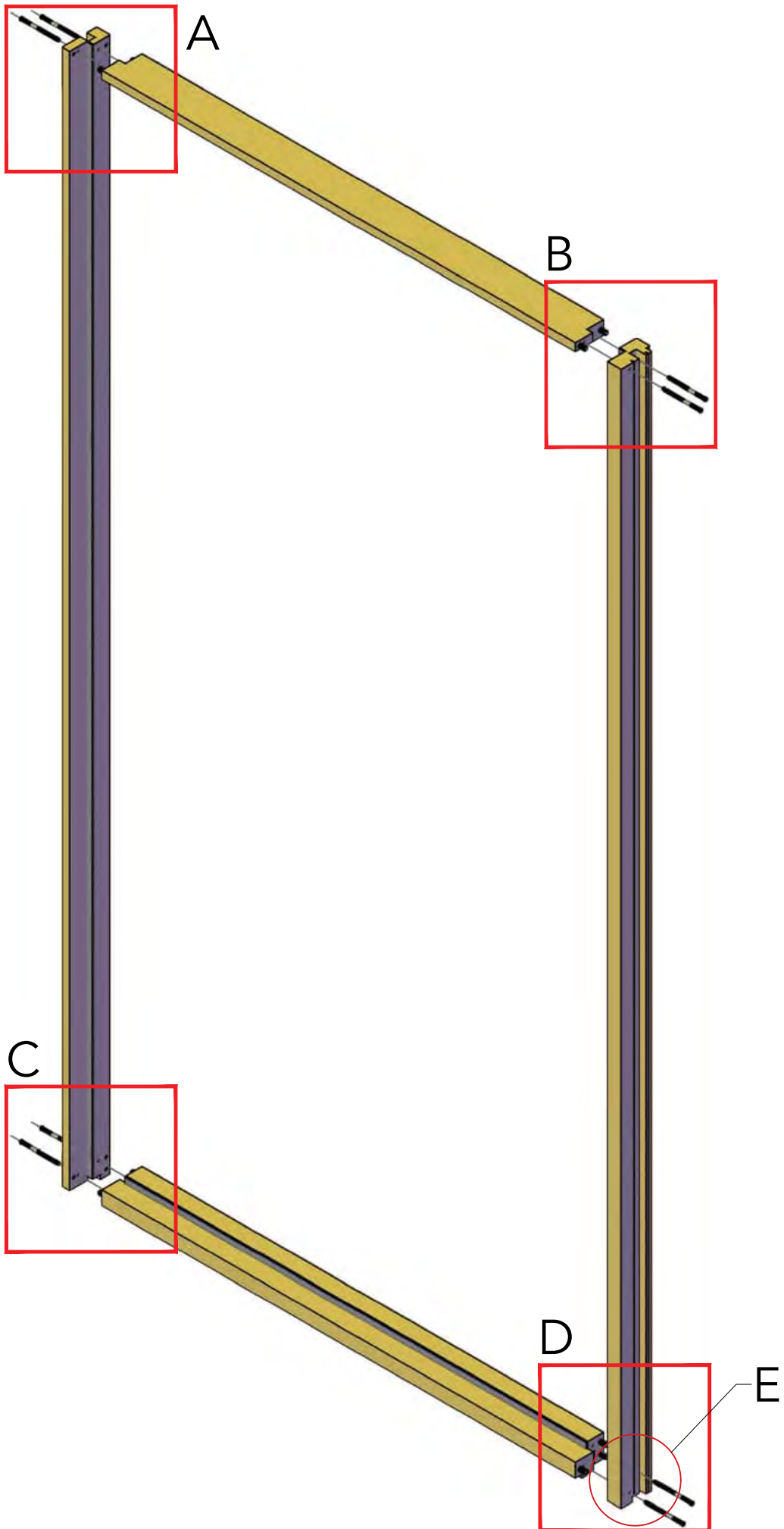

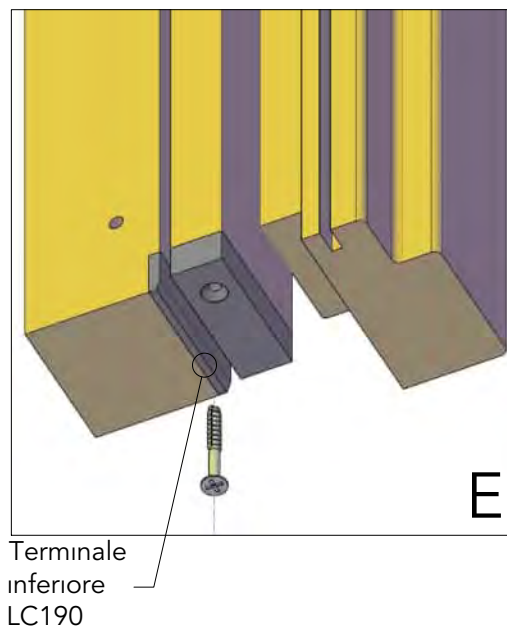
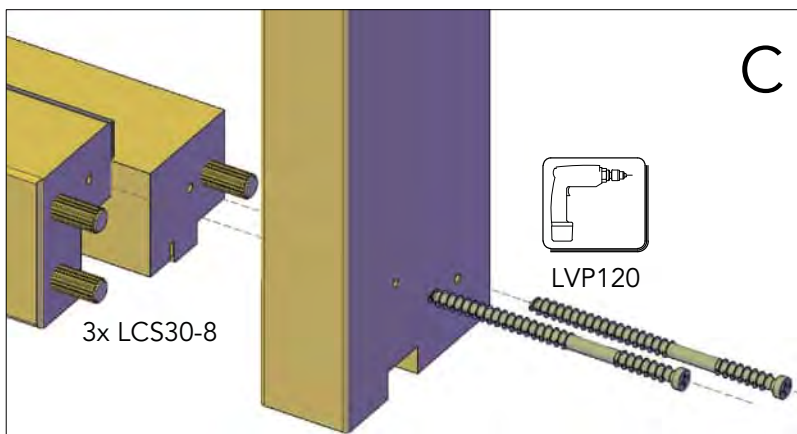
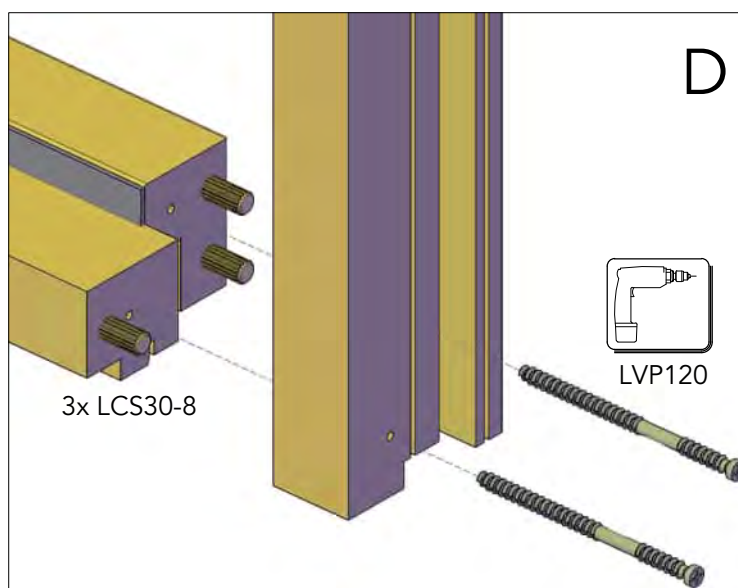
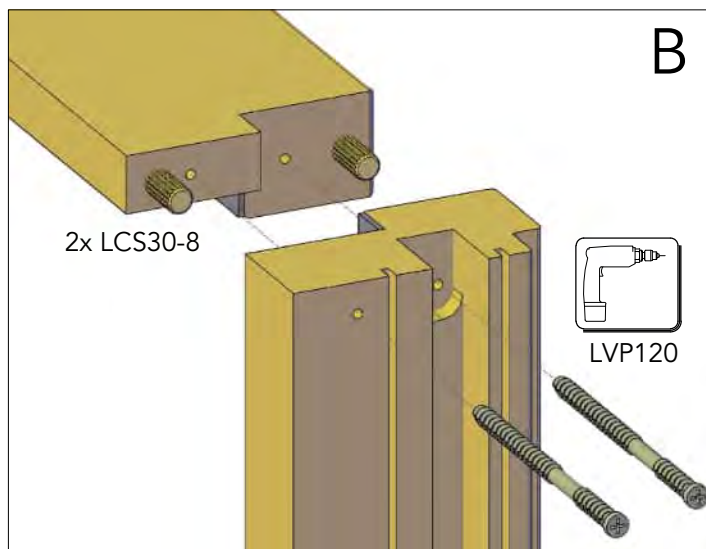
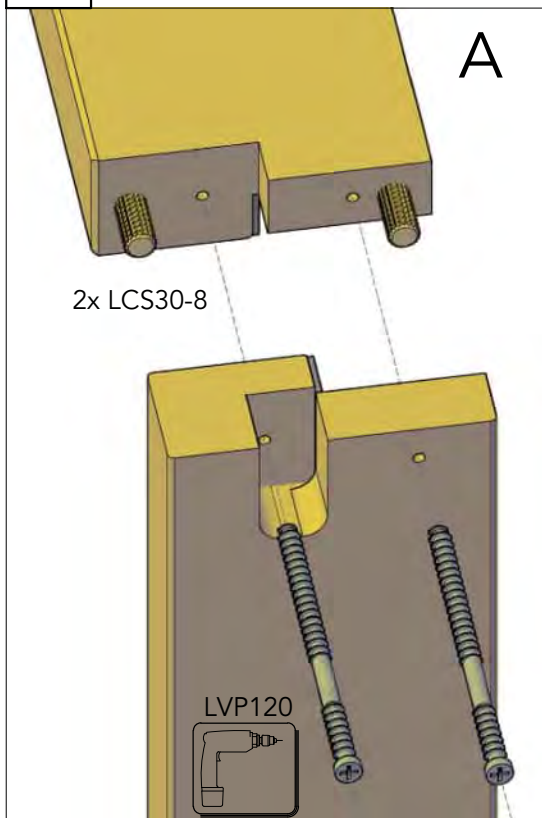

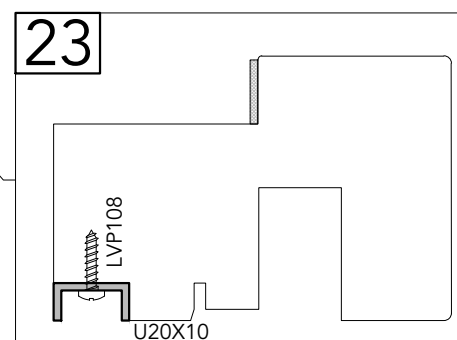
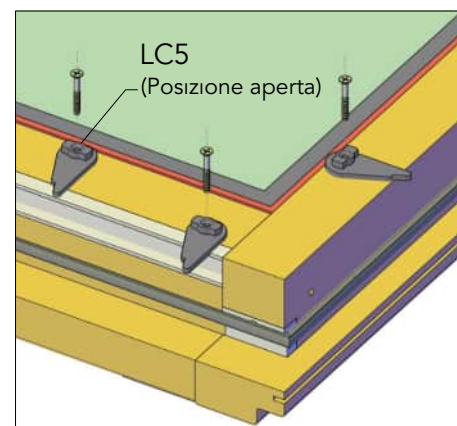
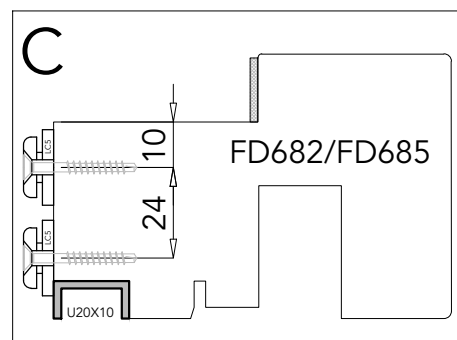
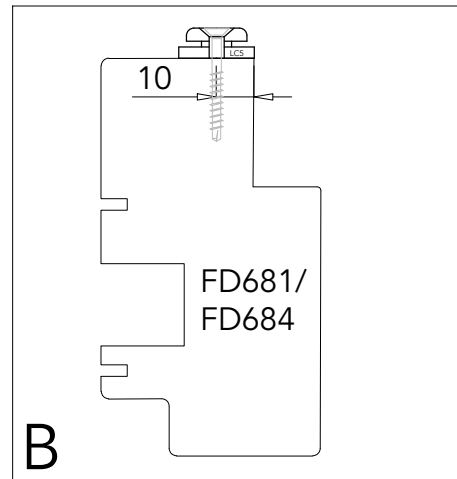
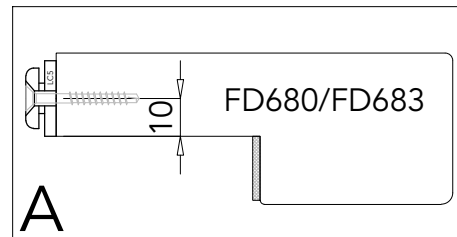
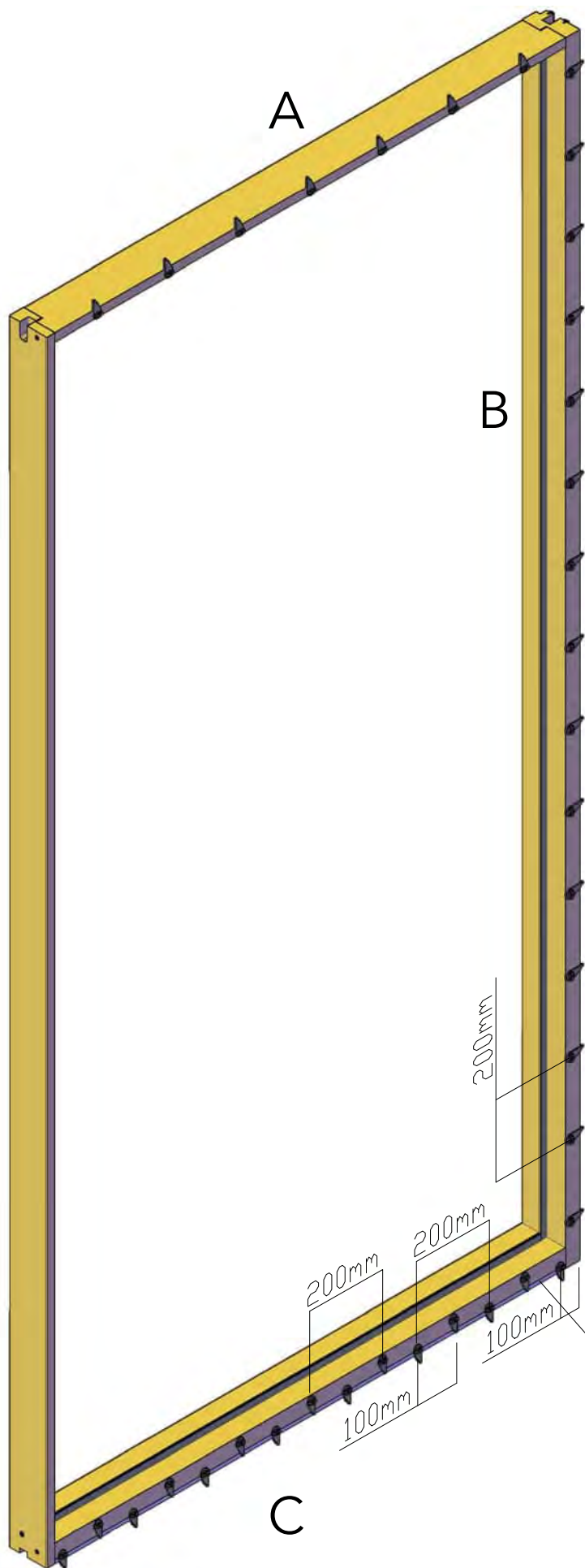

25

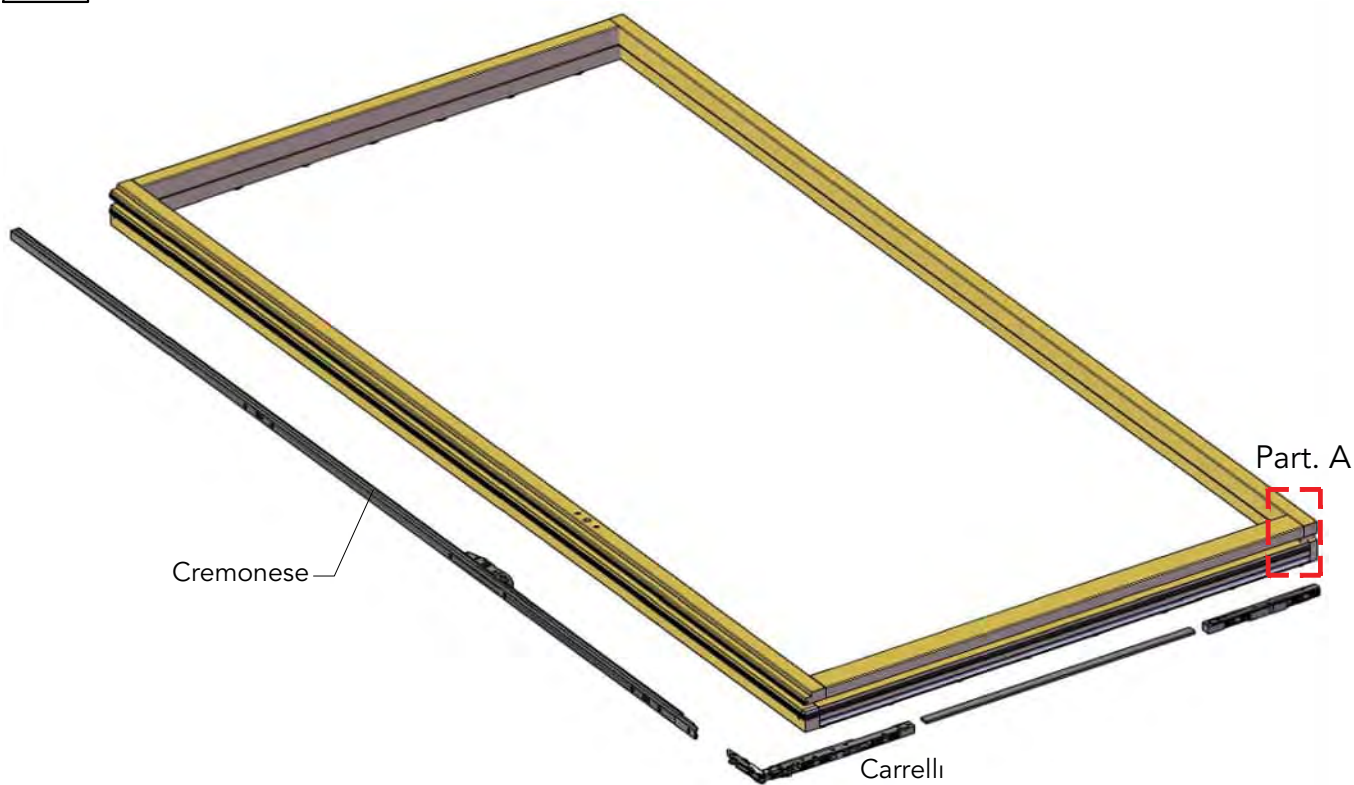

Part. A

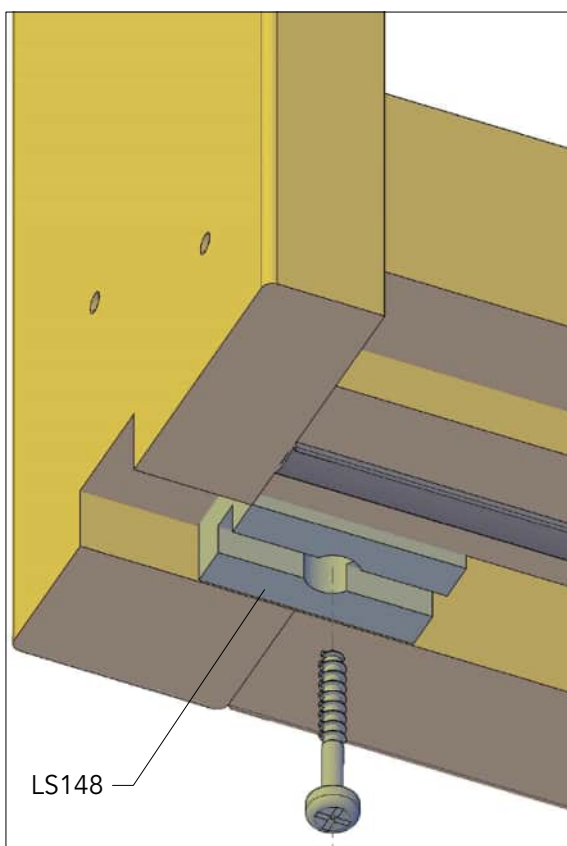

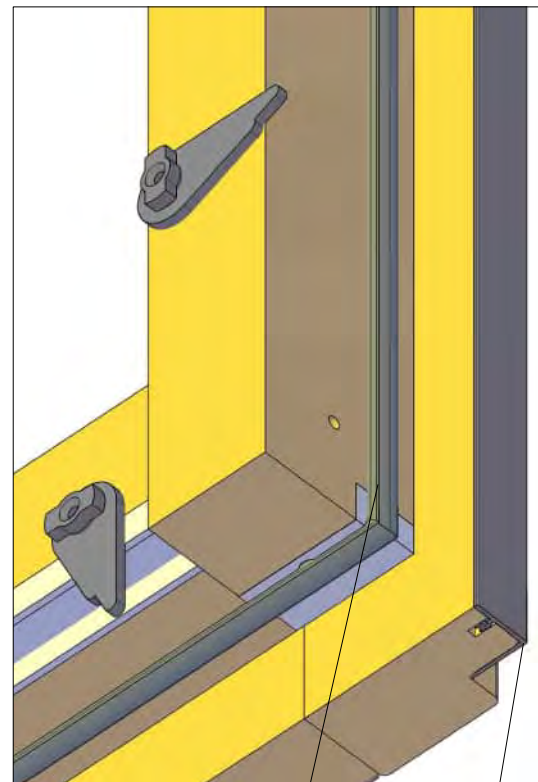
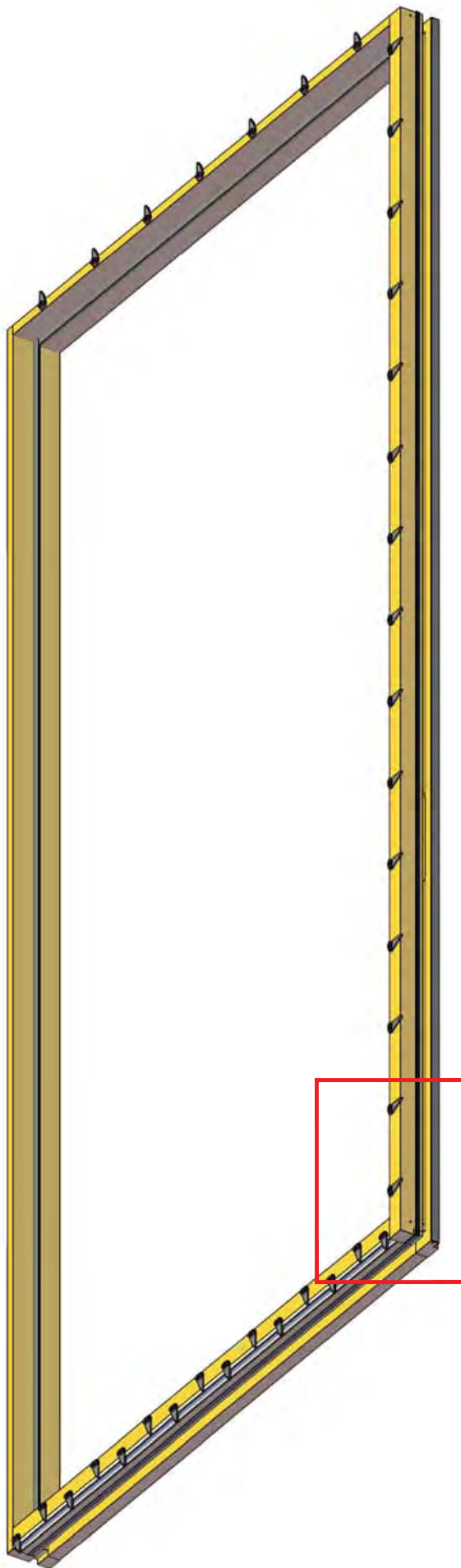

LA669



DE173-E
 Angolo saldato
 Misura 2,5x2,5mt*
 colore nero

Per misure superiori a 2,5mt
 giuntare l'angolo con la
 guarnizione DE173 a metri

27



28

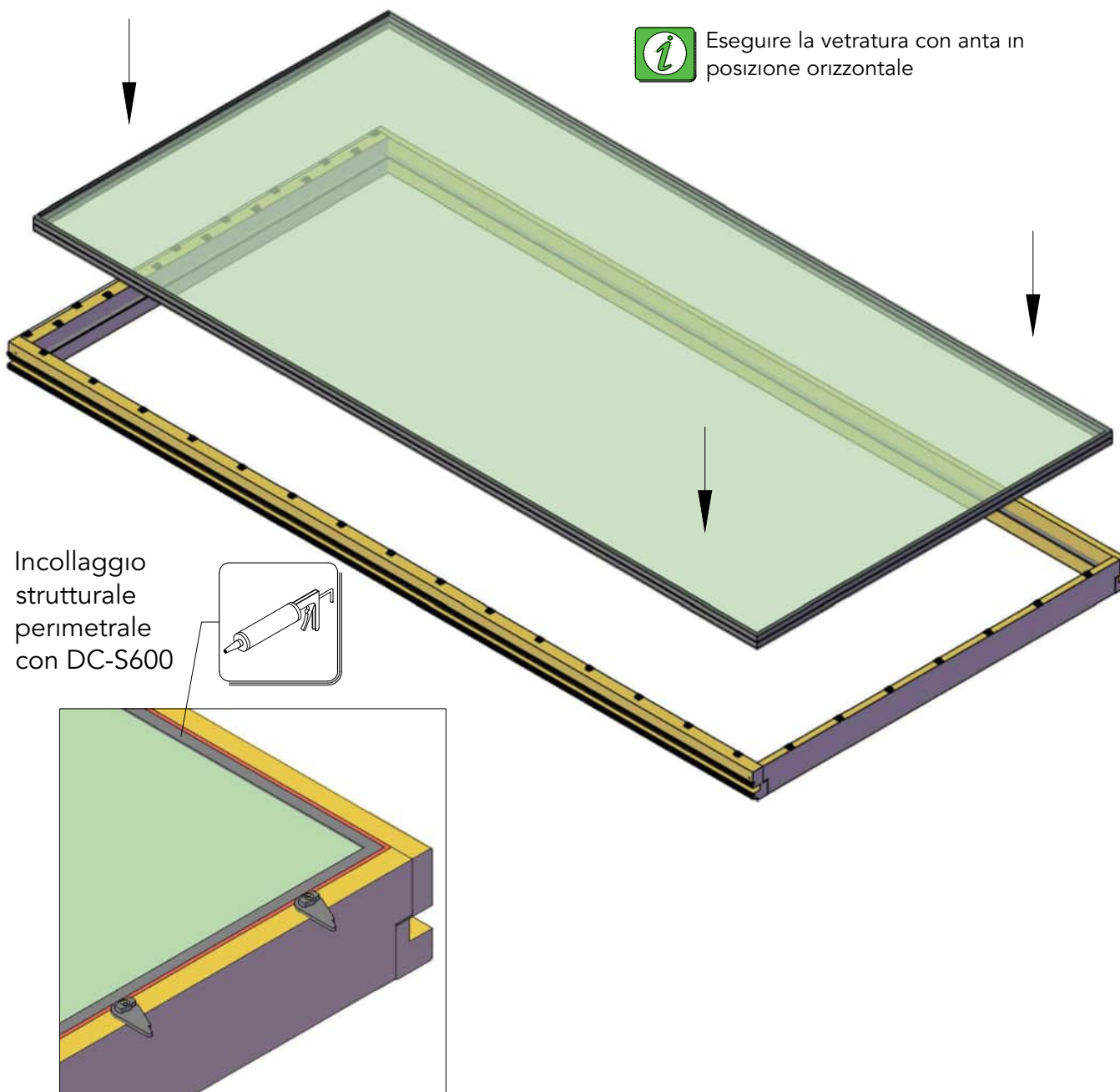

Eeguire la vetratura con anta in posizione orizzontale

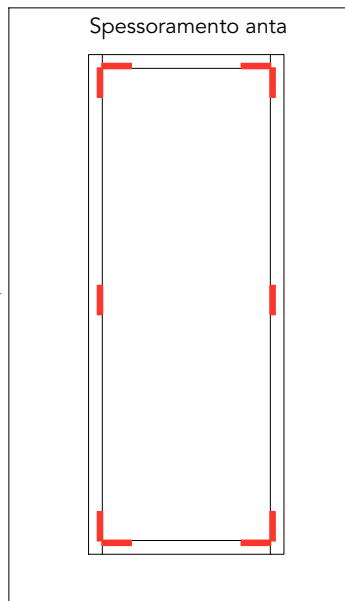

Inserire il vetro e procedere con lo spessoramento (vedi schema seguente)

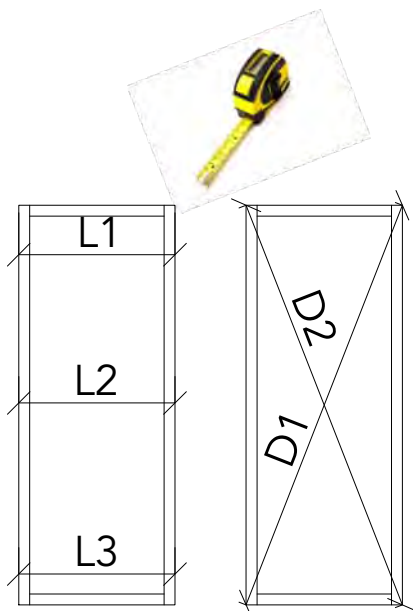

IMPORTANTE:

- verificare la misura esterna dell'anta in più punti, spessorare in maniera uniforme in modo da mantenere i montanti e traversi perpendicolari tra loro ($L1 = L2 = L3$)
- verificare che le 2 diagonali sull'anta siano uguali ($D1 = D2$)

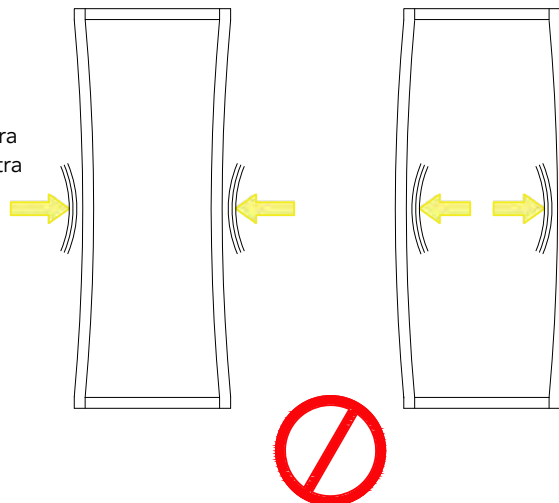

30

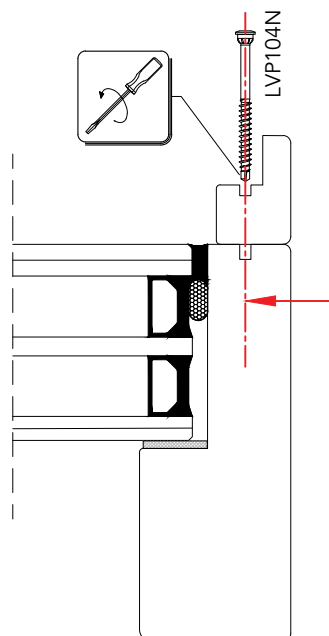
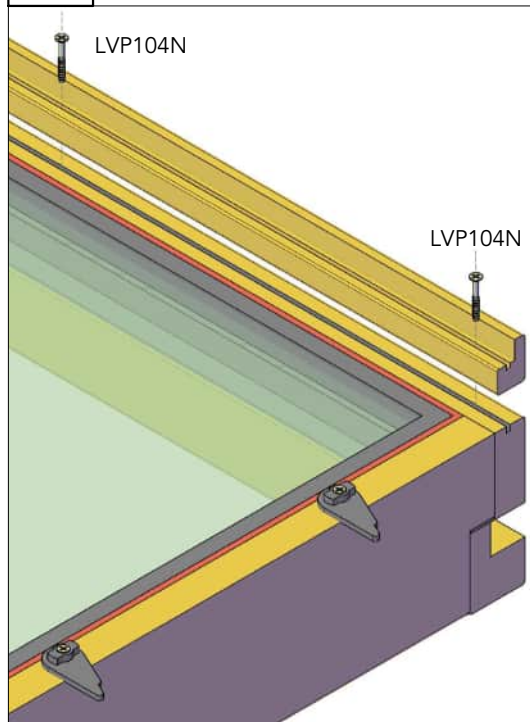

Fissare FD715 con vite LVP104N
passo 300mm

31

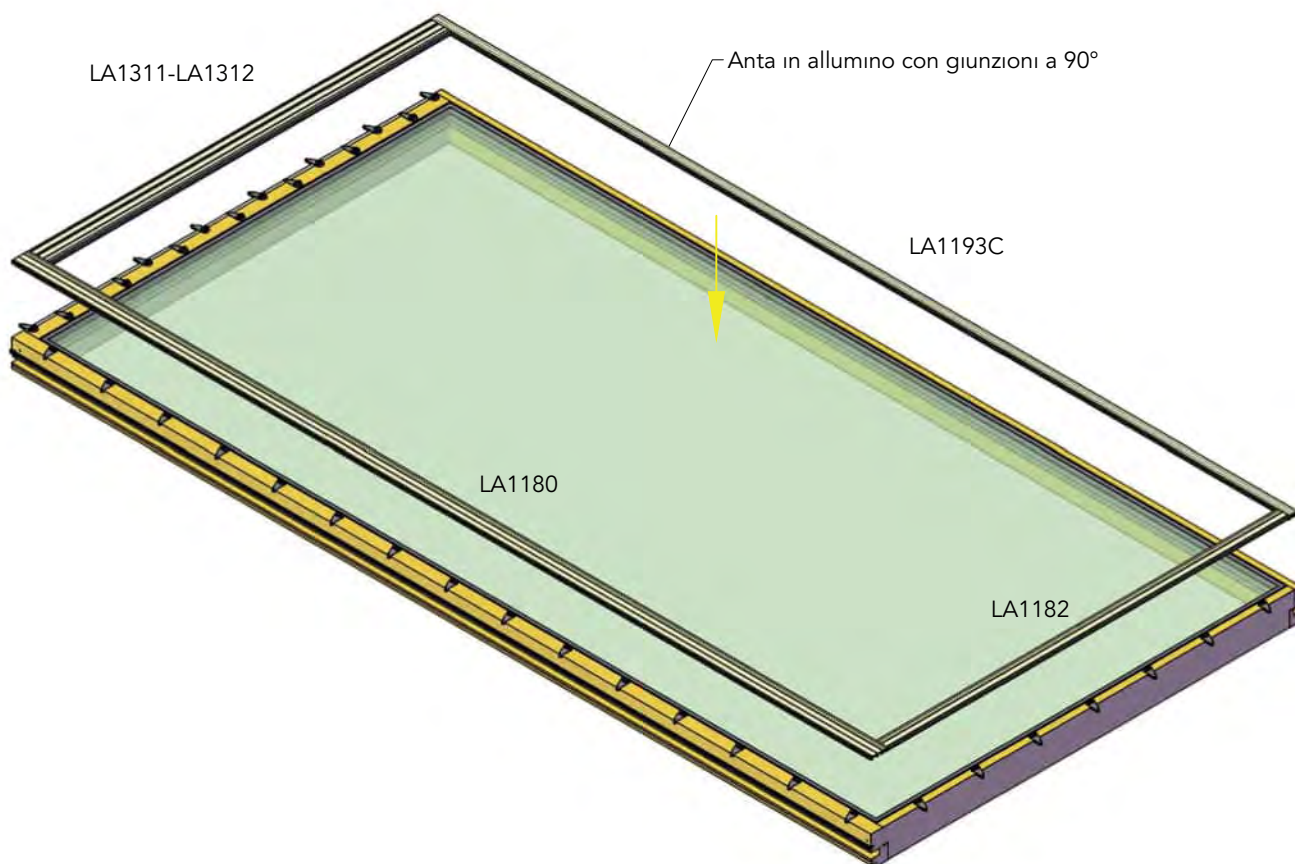

31

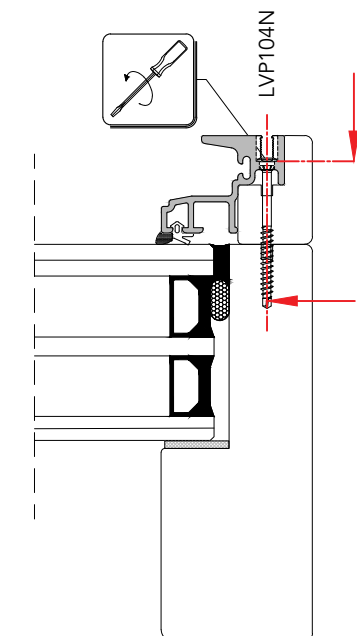
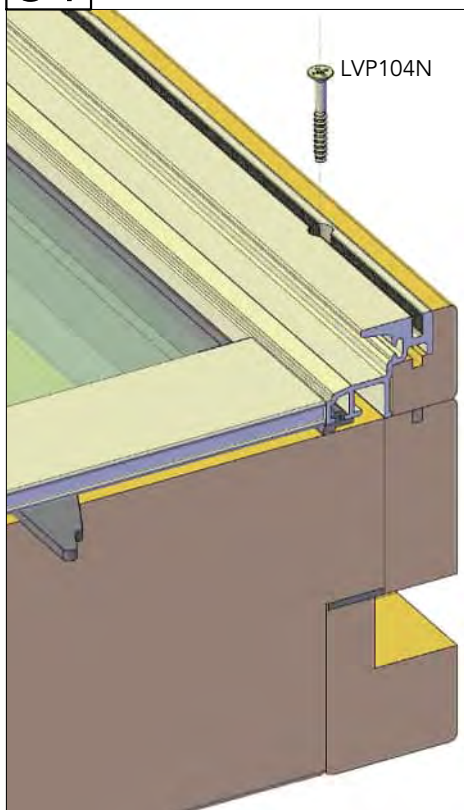

Fissare LA1193c con vite LVP104N passo 300mm

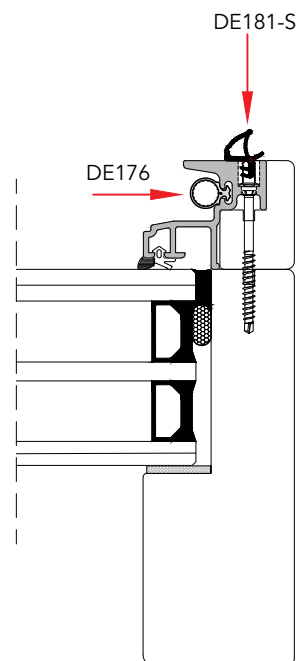

Montare le guarnizioni DE181-S e DE176

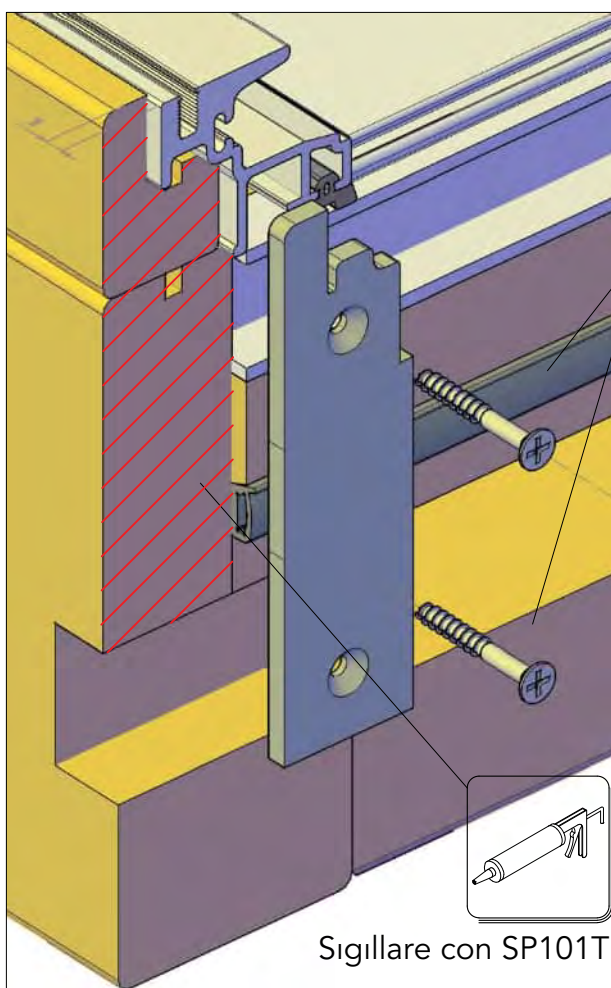

Sigillare con SP101T

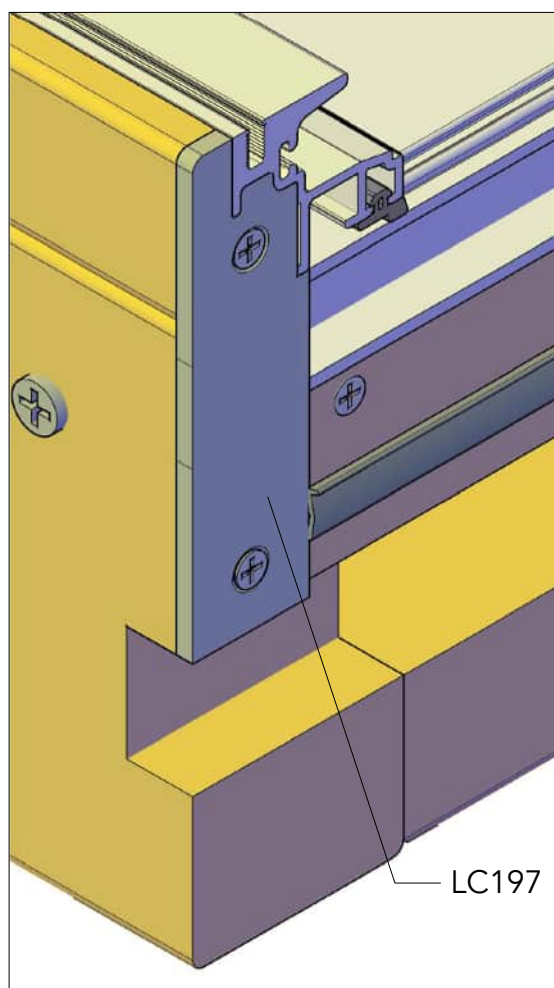

LC197

32

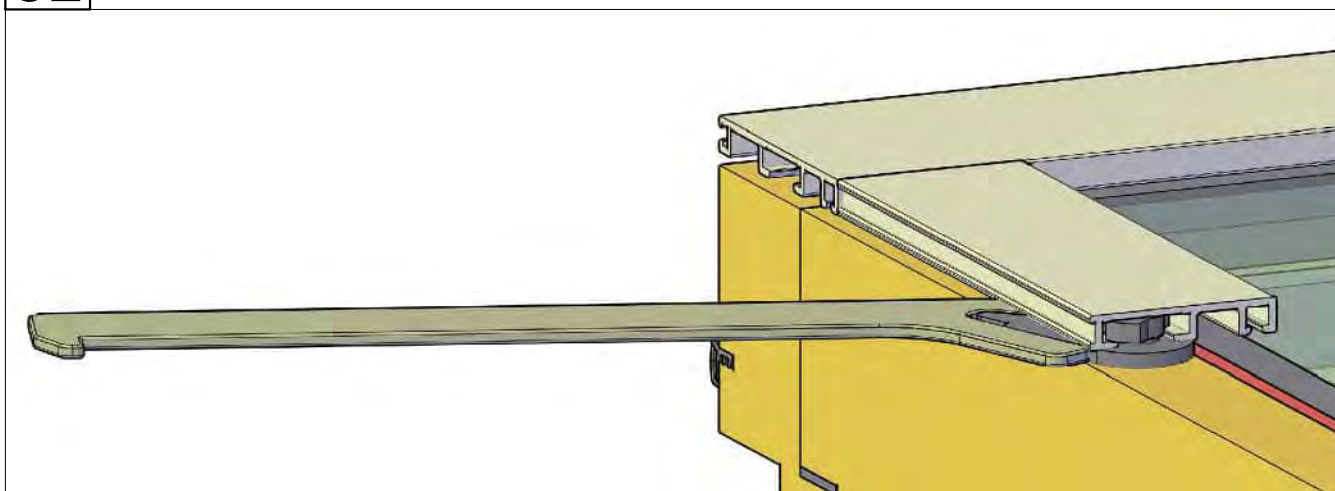

Ruotare le clips sui 3 lati con LD66 per bloccare il telaio in alluminio

33

Anta -lato superiore-

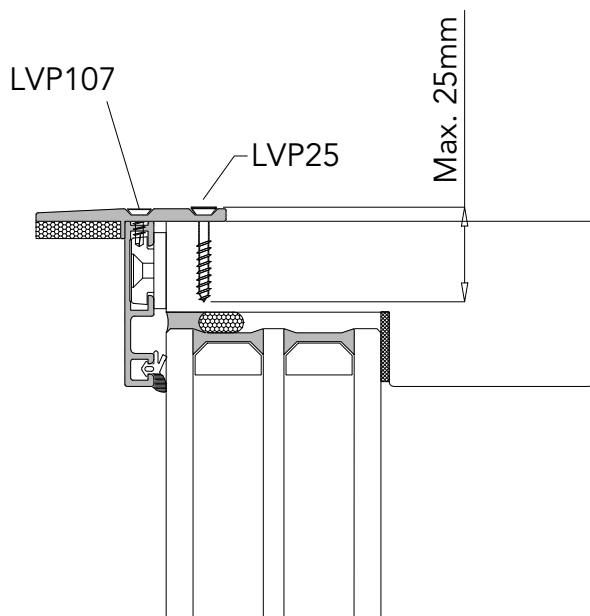
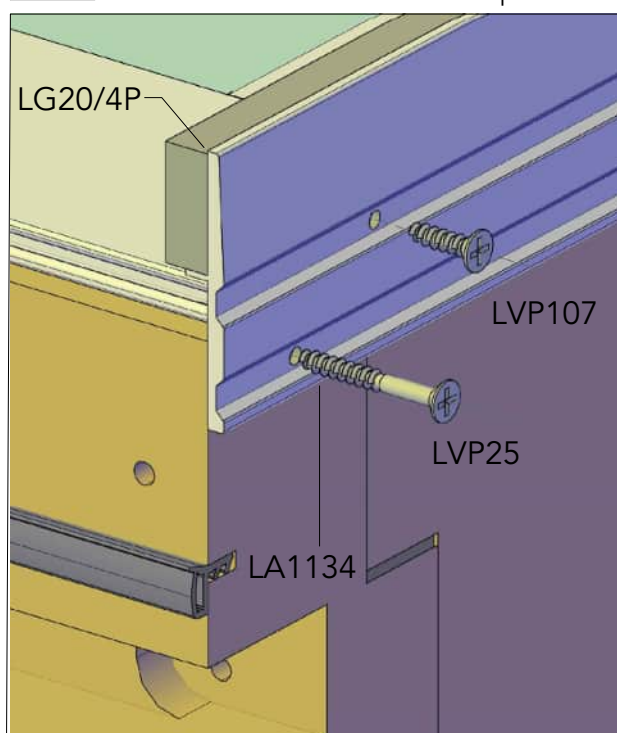

Anta -lato superiore-

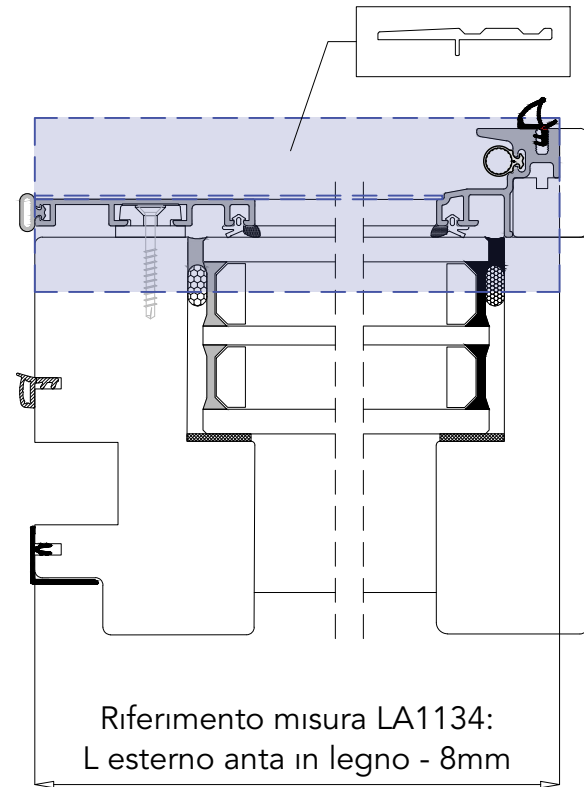
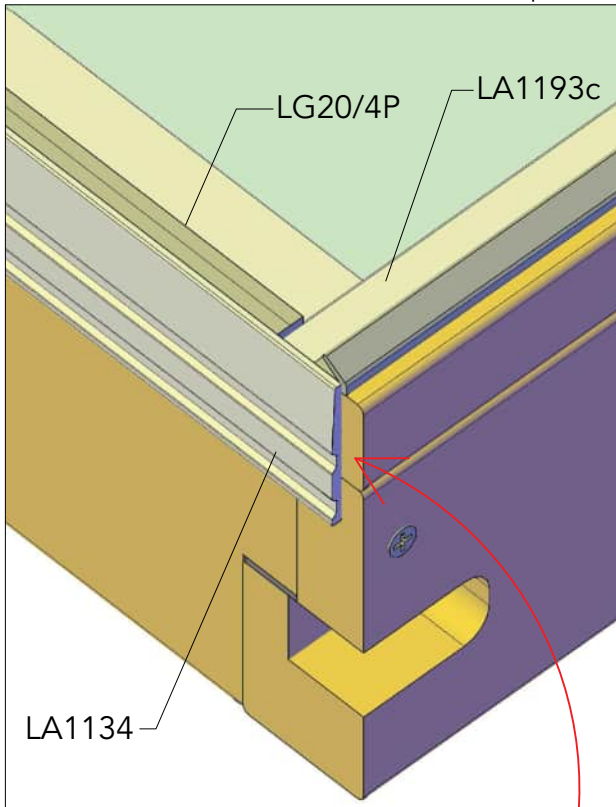

Riferimento misura LA1134:
L esterno anta in legno - 8mm

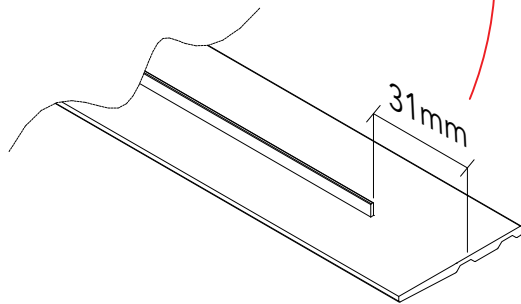

Lavorazione fresatura LA1134:
T015-098

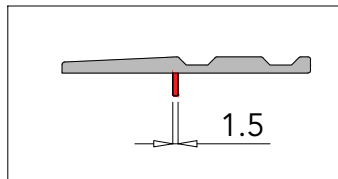

34

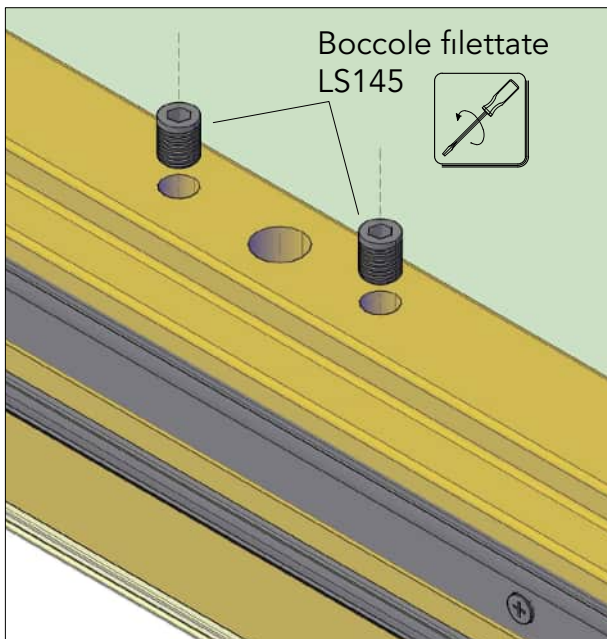

Boccole filettate
LS145

Fissaggio del maniglione anta

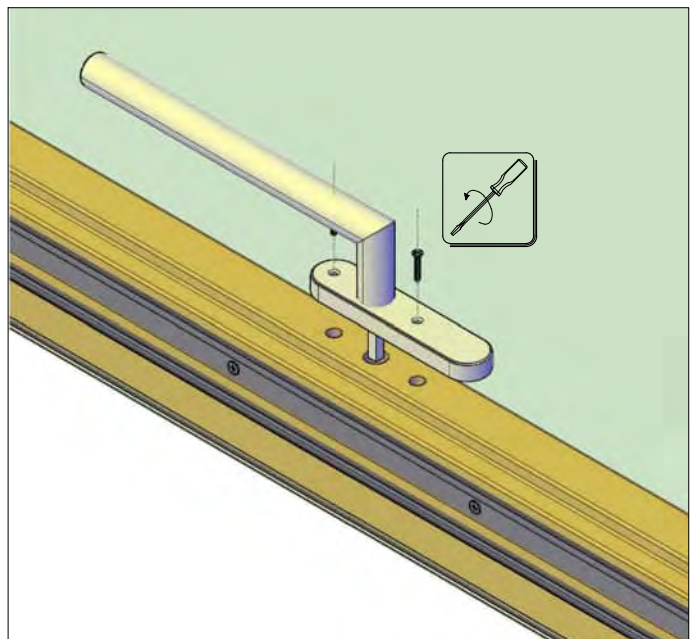

35

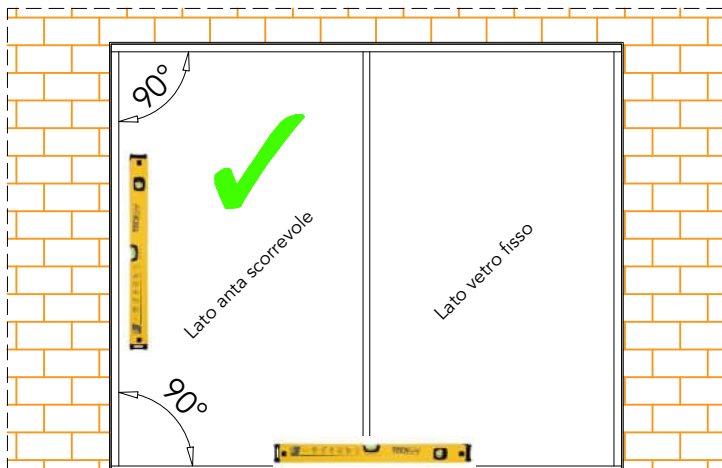

Posizionare il telaio, mettere in bolla e spessorare

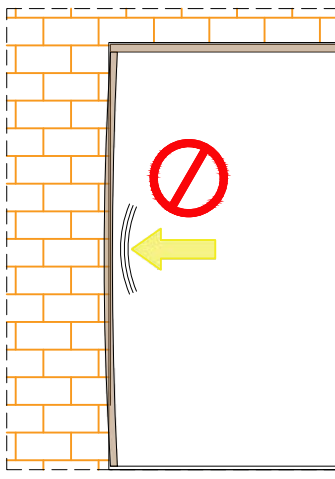
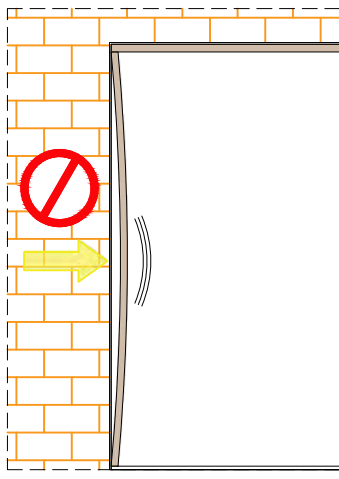

Durante la fase di fissaggio alla muratura, accertarsi che non si verifichino spancamenti nei montanti soprattutto nel lato telaio di chiusura dell'anta scorrevole

36

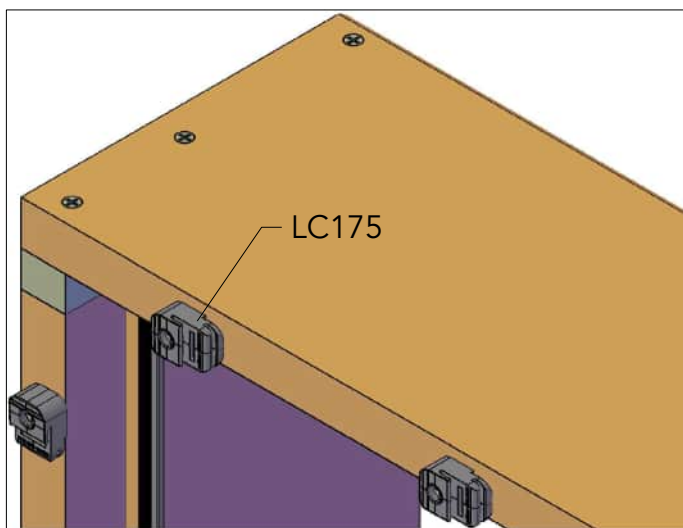

37

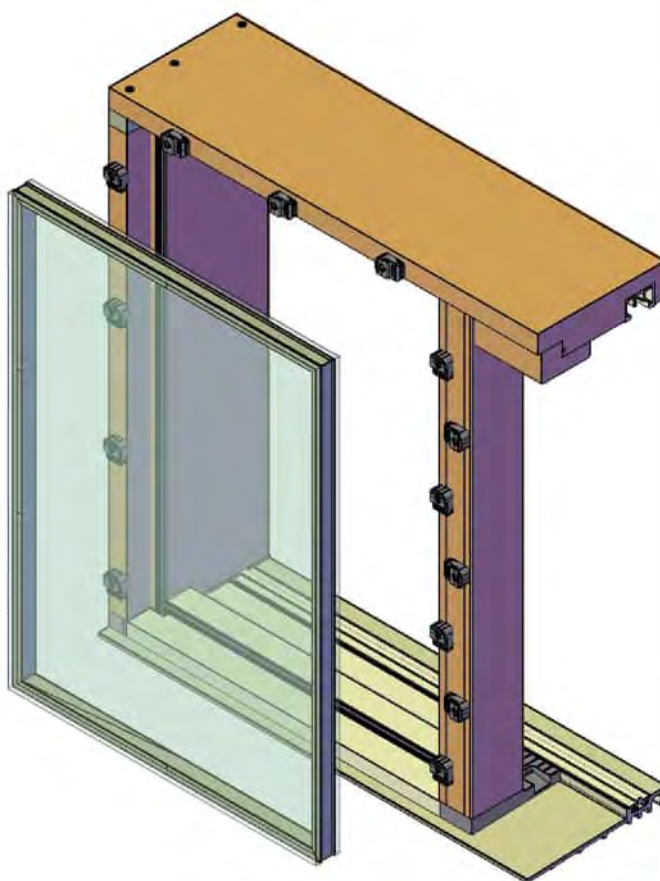

38

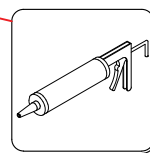
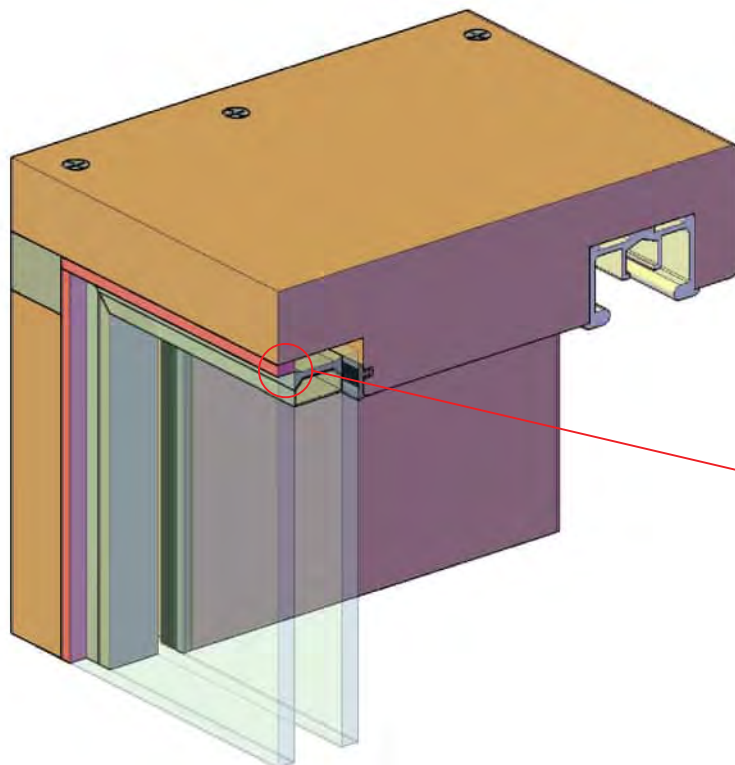

Incollaggio
strutturale
perimetrale con
DC-S600

39

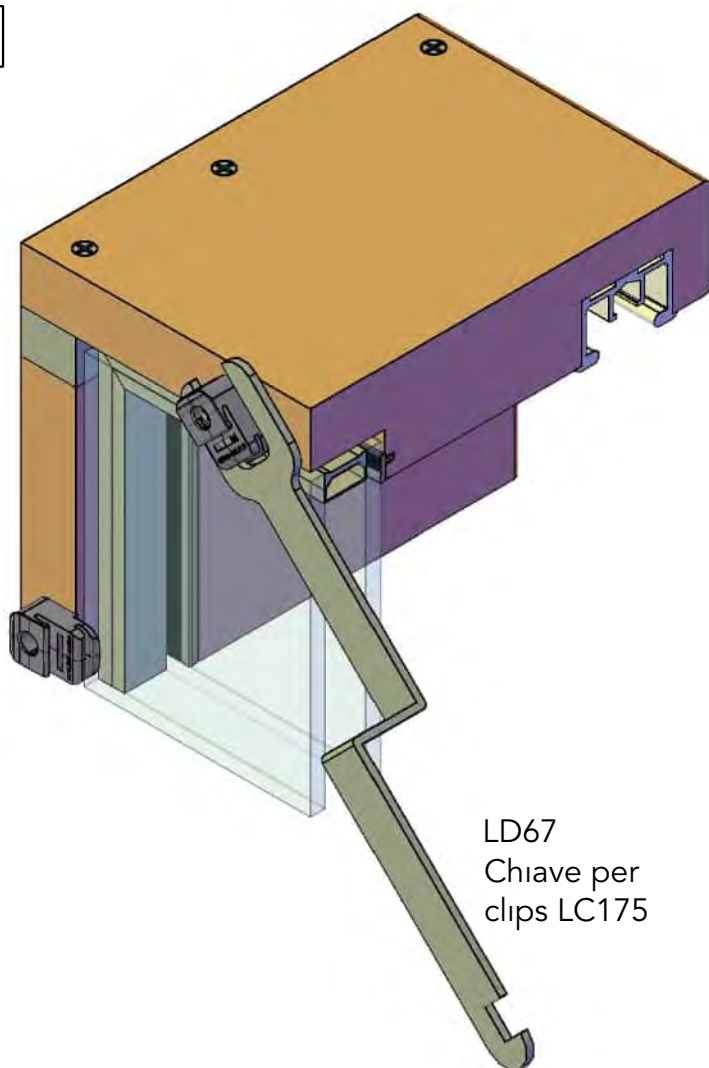

LD67
Chiave per
clips LC175

40

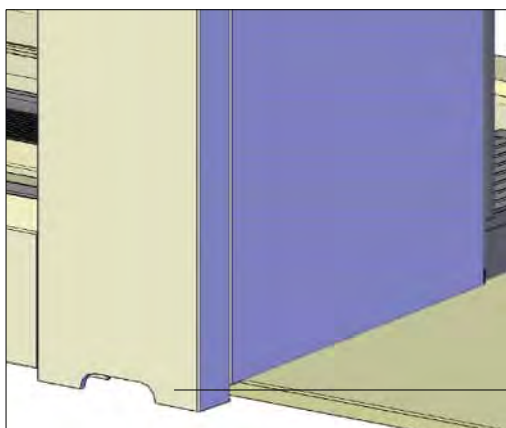
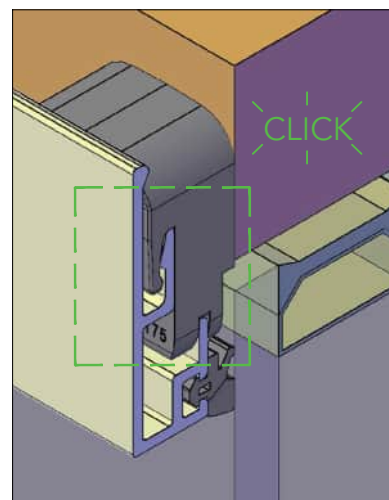
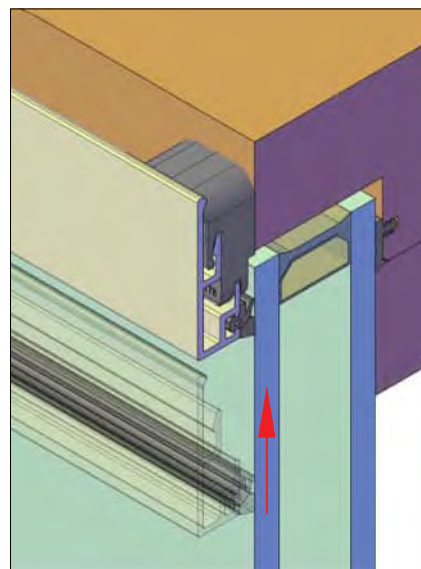
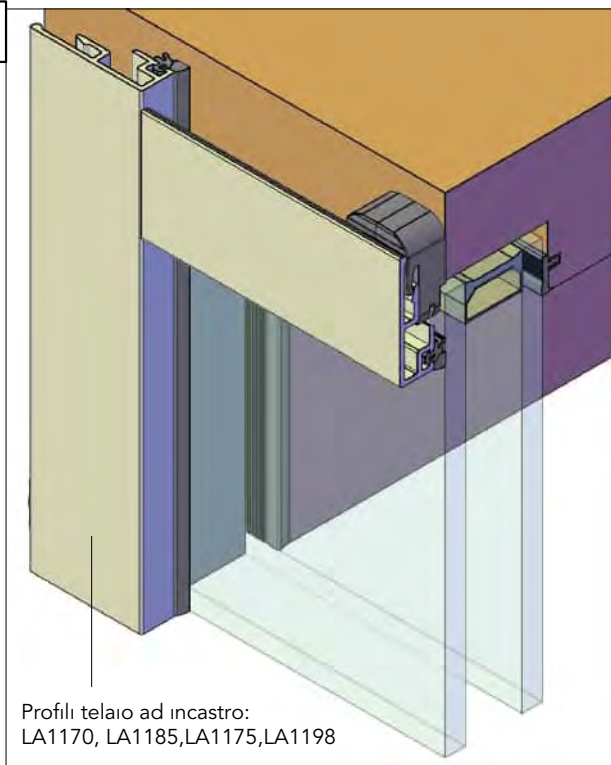

Per la rimozione del vetro in caso di sostituzione:

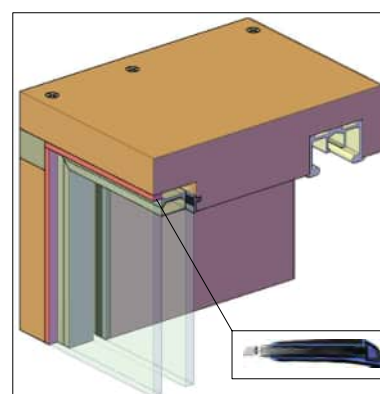
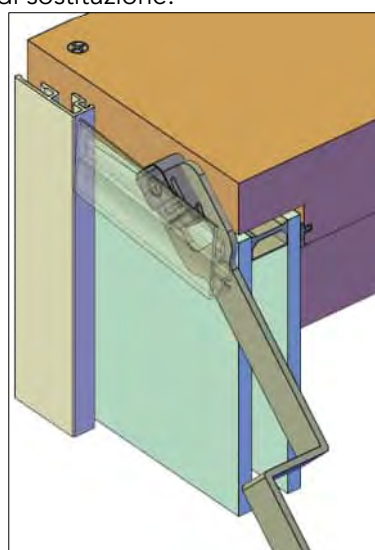
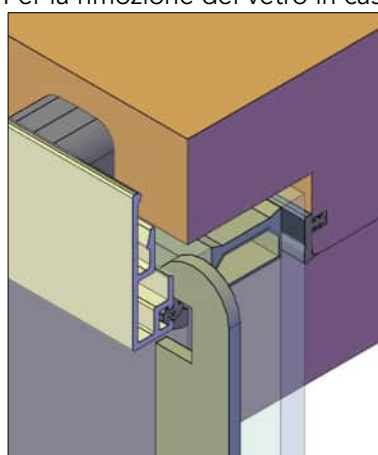

41

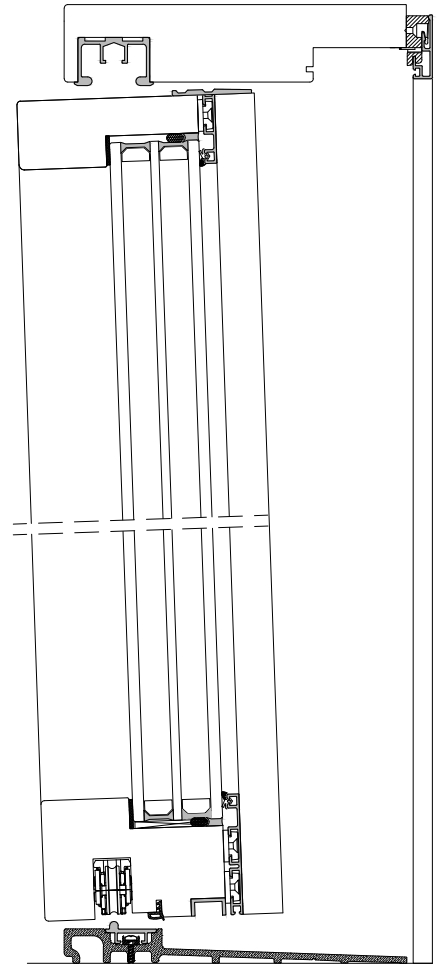
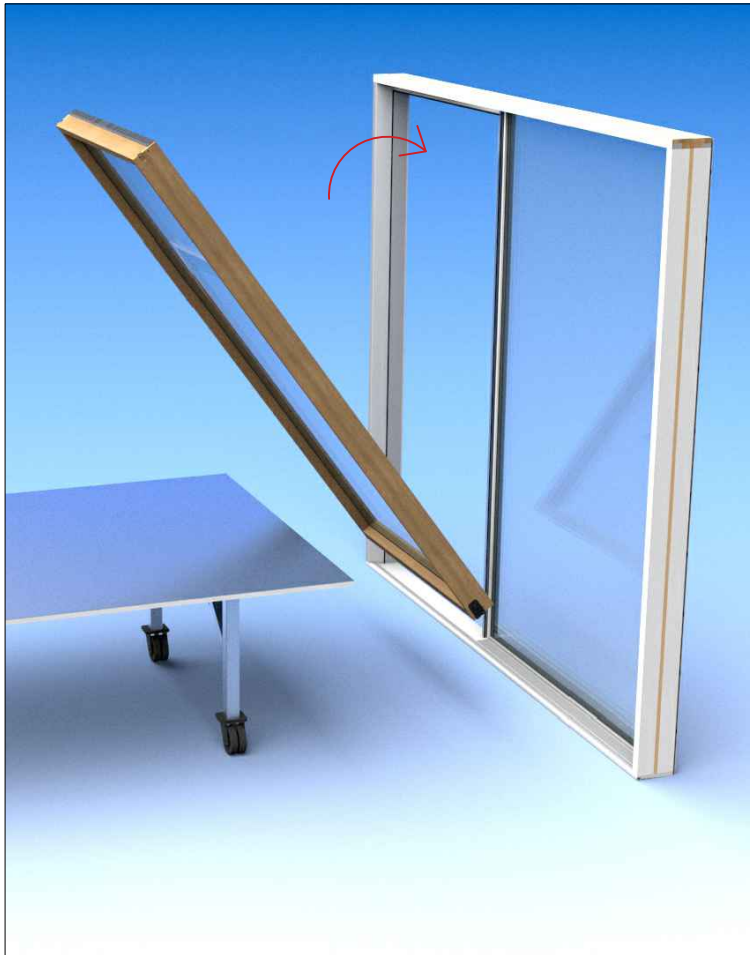

LC195-Carrello guida su lato maniglia

LC195-Carrello guida su lato interno

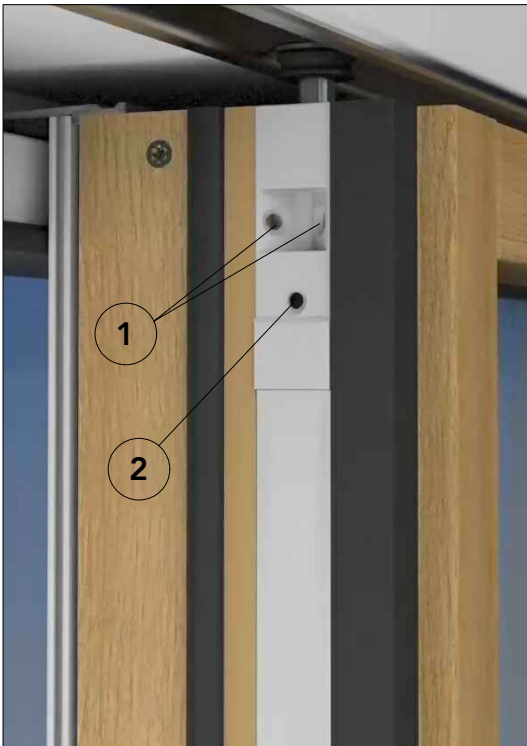

1 Montaggio con viti 4x20mm 2 Montaggio con viti 4x35mm

41

LC196-Kit piastre di copertura in acciaio lucido



LC196-Lato inferiore



LC196-Lato superiore



Paracolpi a scomparsa

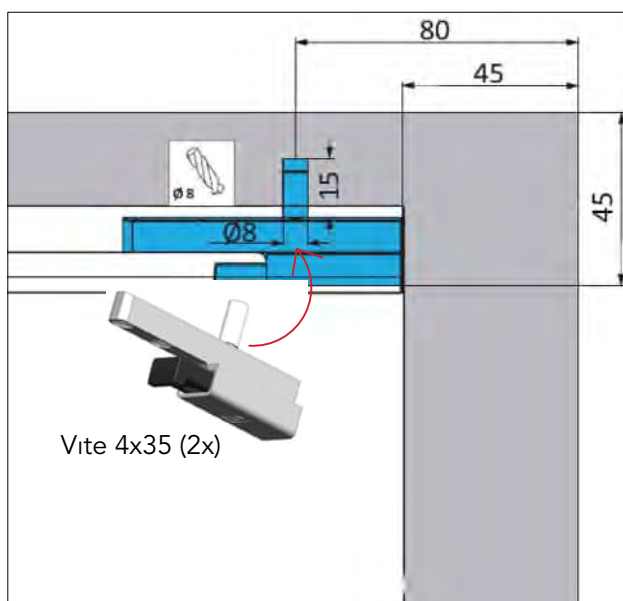

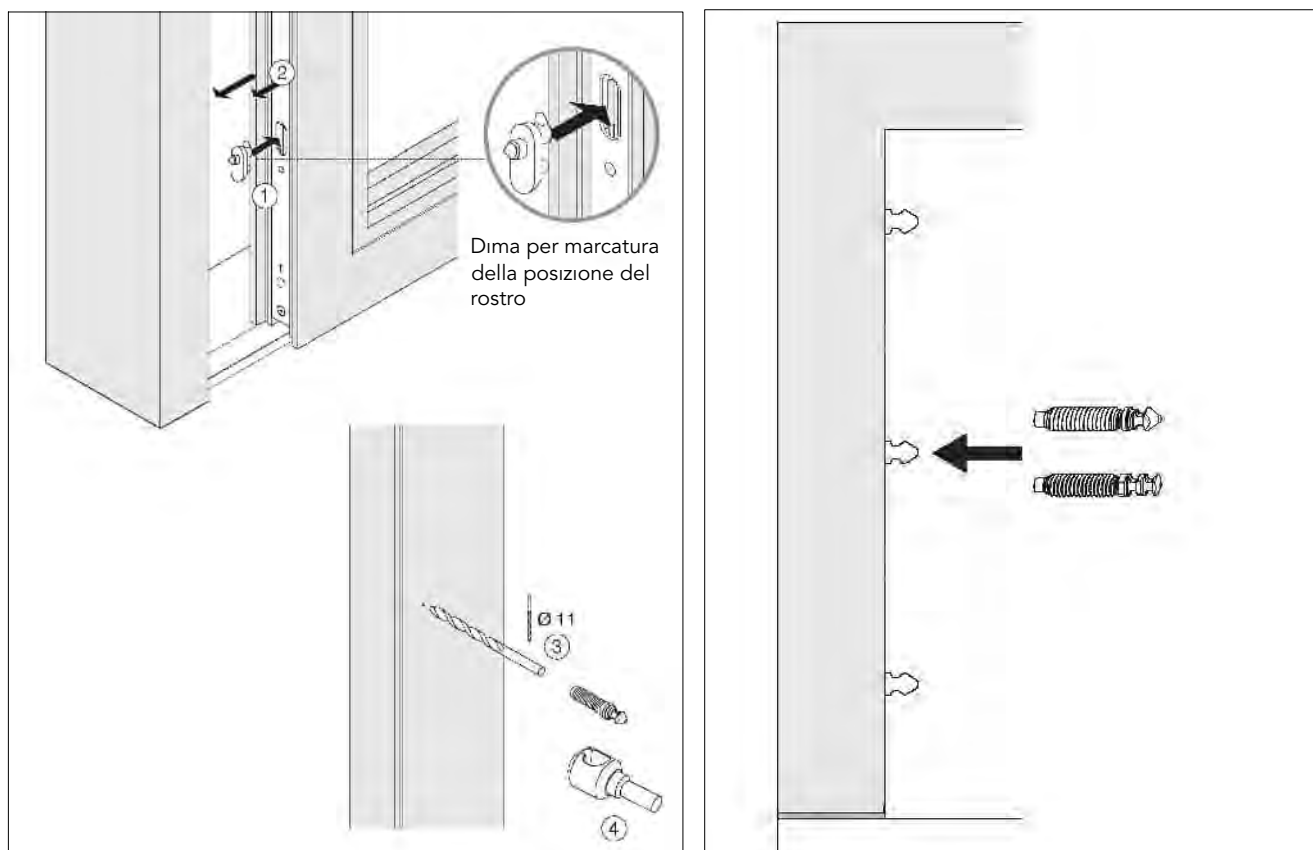

Variante rostro di chiusura per serratura a ganci

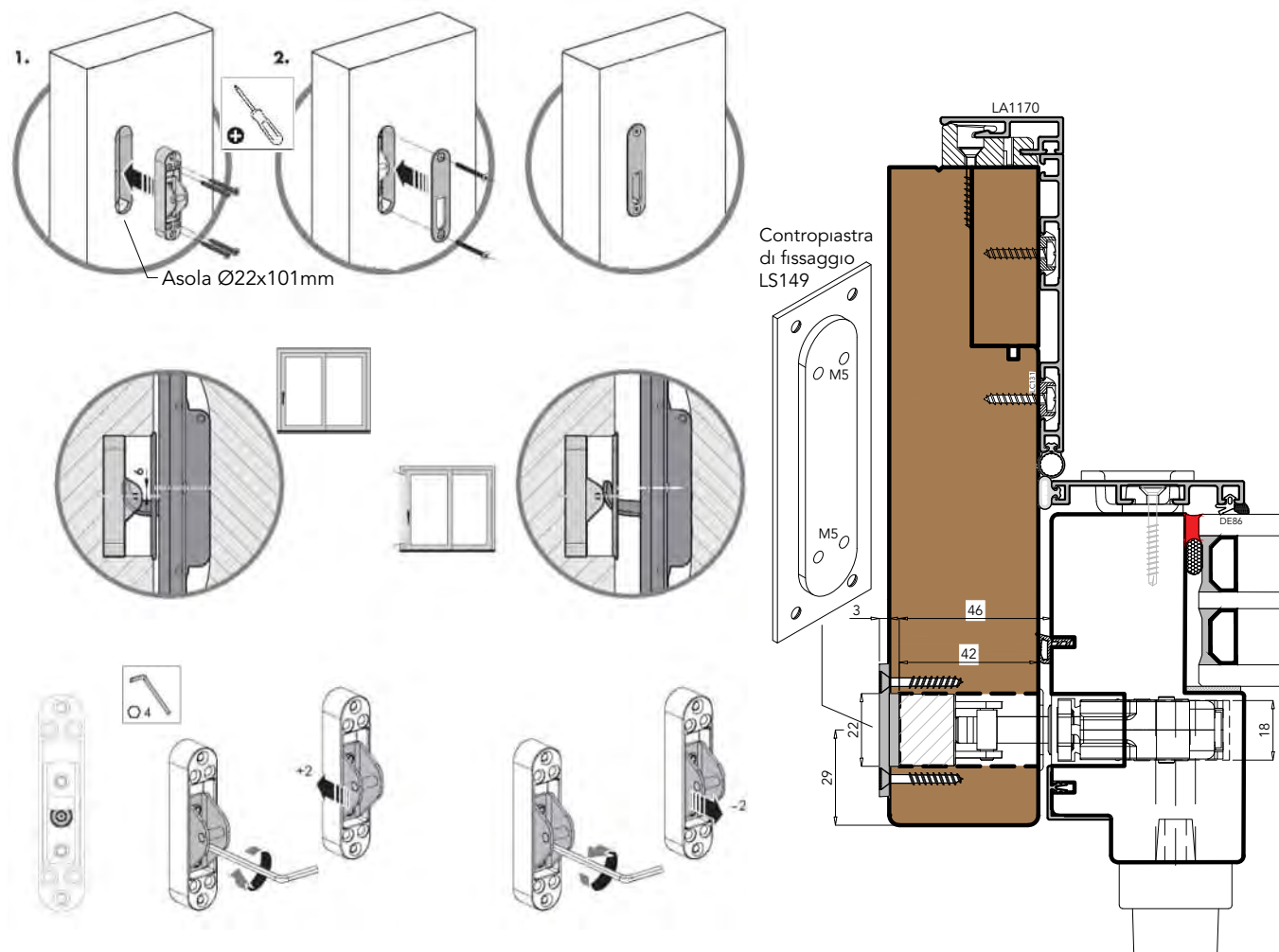

43

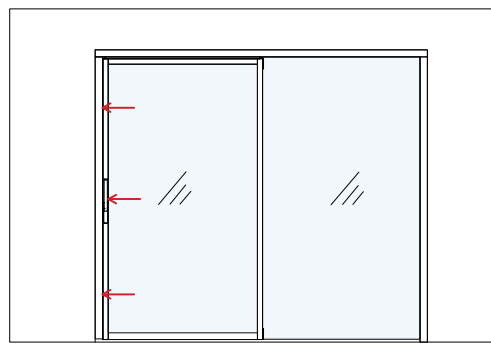

1. Verificare chiusura

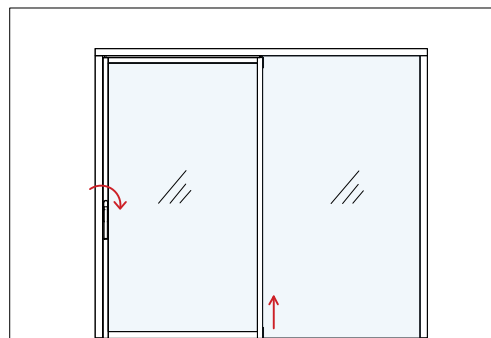

2. Verificare apertura e sollevamento

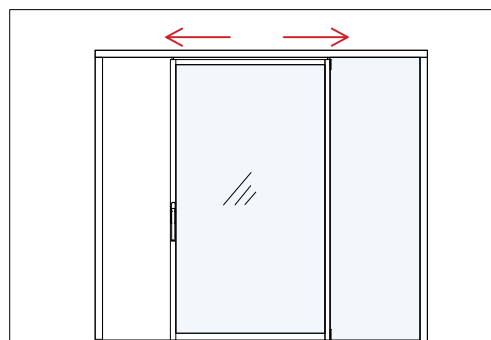

3. Verificare scorrimento

44

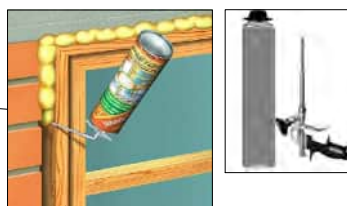
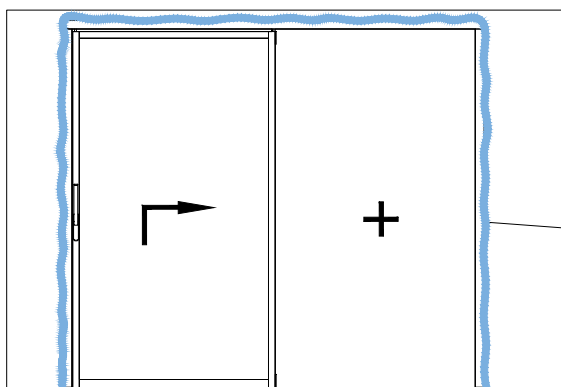

Coprifili in legno interni

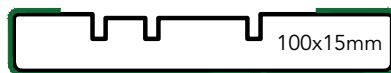
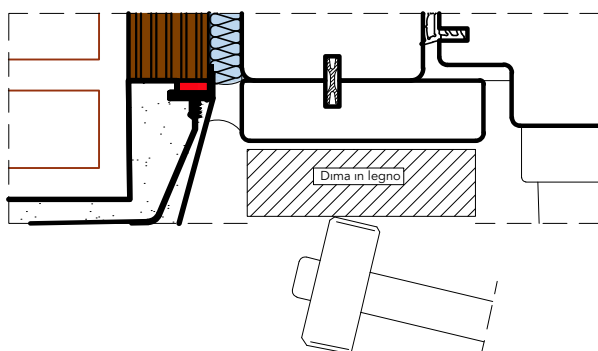

FD690

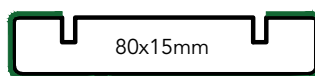

FD689

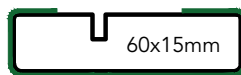

FD691



FD697

Riepiloghi
Summary

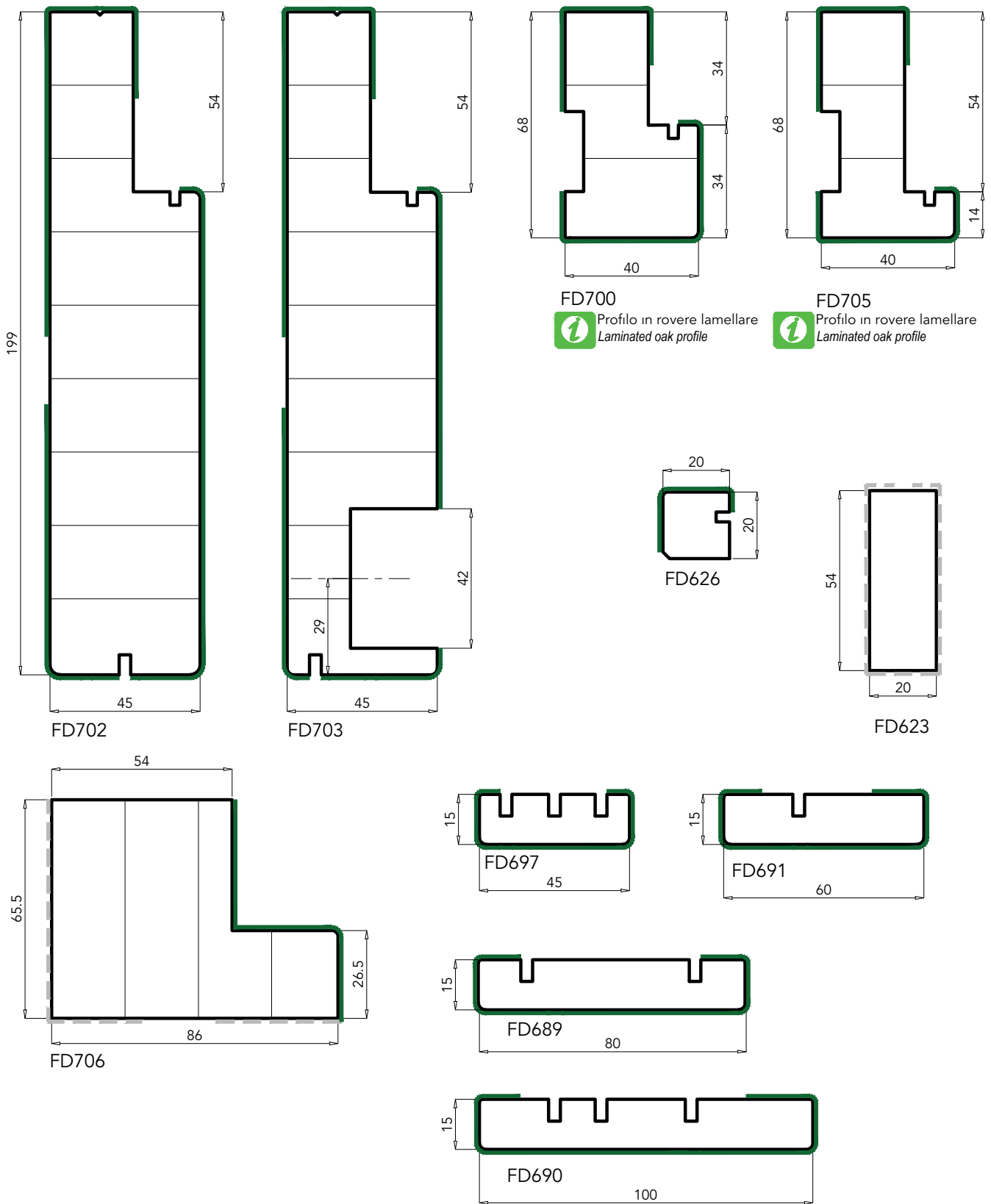

uni_one90° HS magis40

uniform

Scala -

- (IT) Profili in legno
- (DE) Holzprofile
- (ES) Perfiles en madera
- (FR) Profils en bois
- (UK) Wood profiles

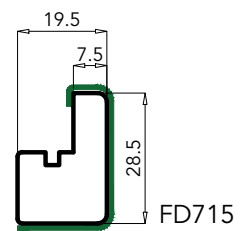
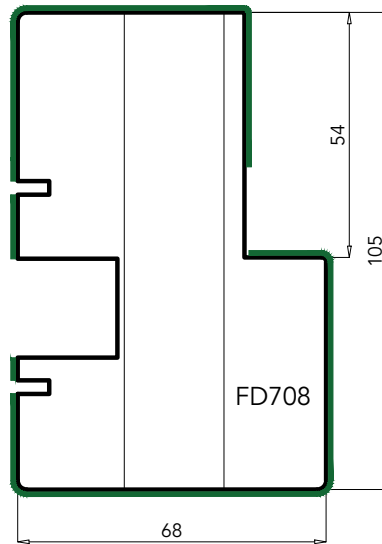
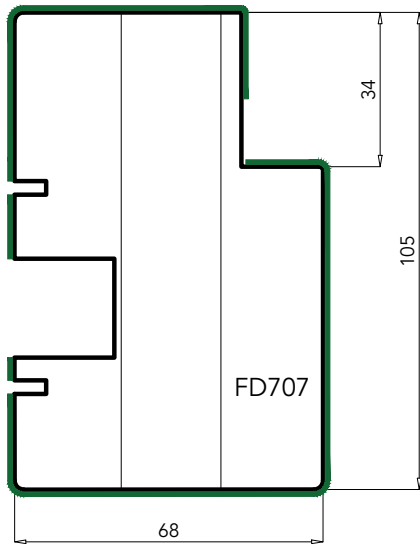
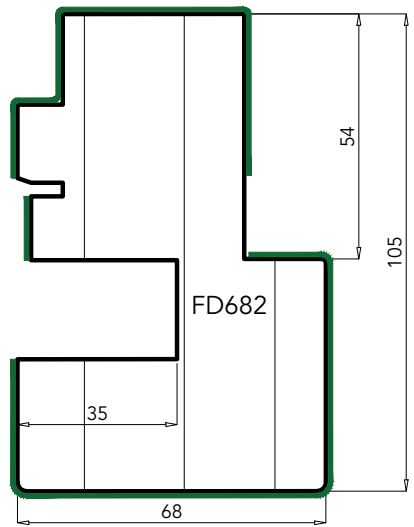
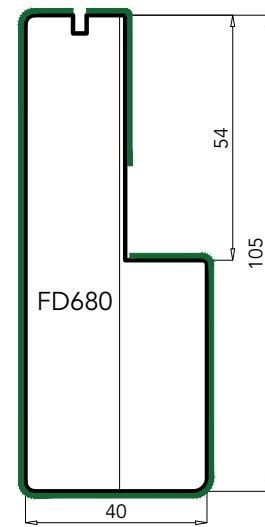
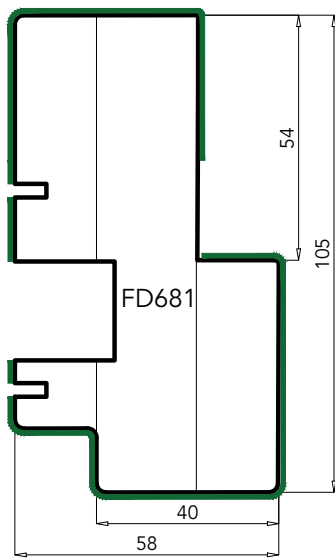
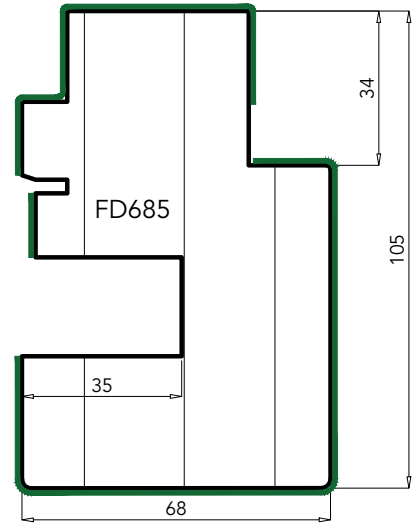
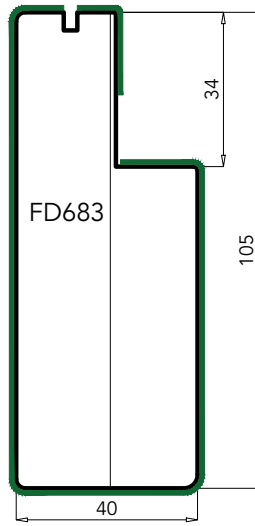
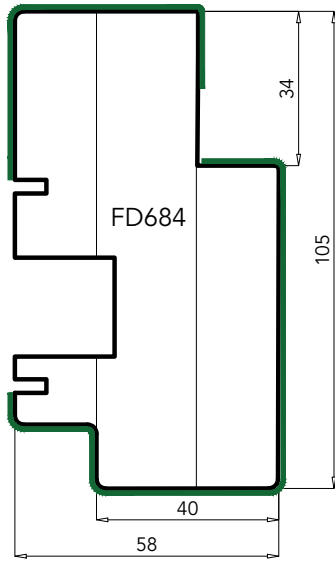

uni_one90° HS magis40



Scala -

- (IT) Profili in legno
- (DE) Holzprofile
- (ES) Perfiles en madera
- (FR) Profils en bois
- (UK) Wood profiles

LAVORAZIONI STEMA SULL'ANTA

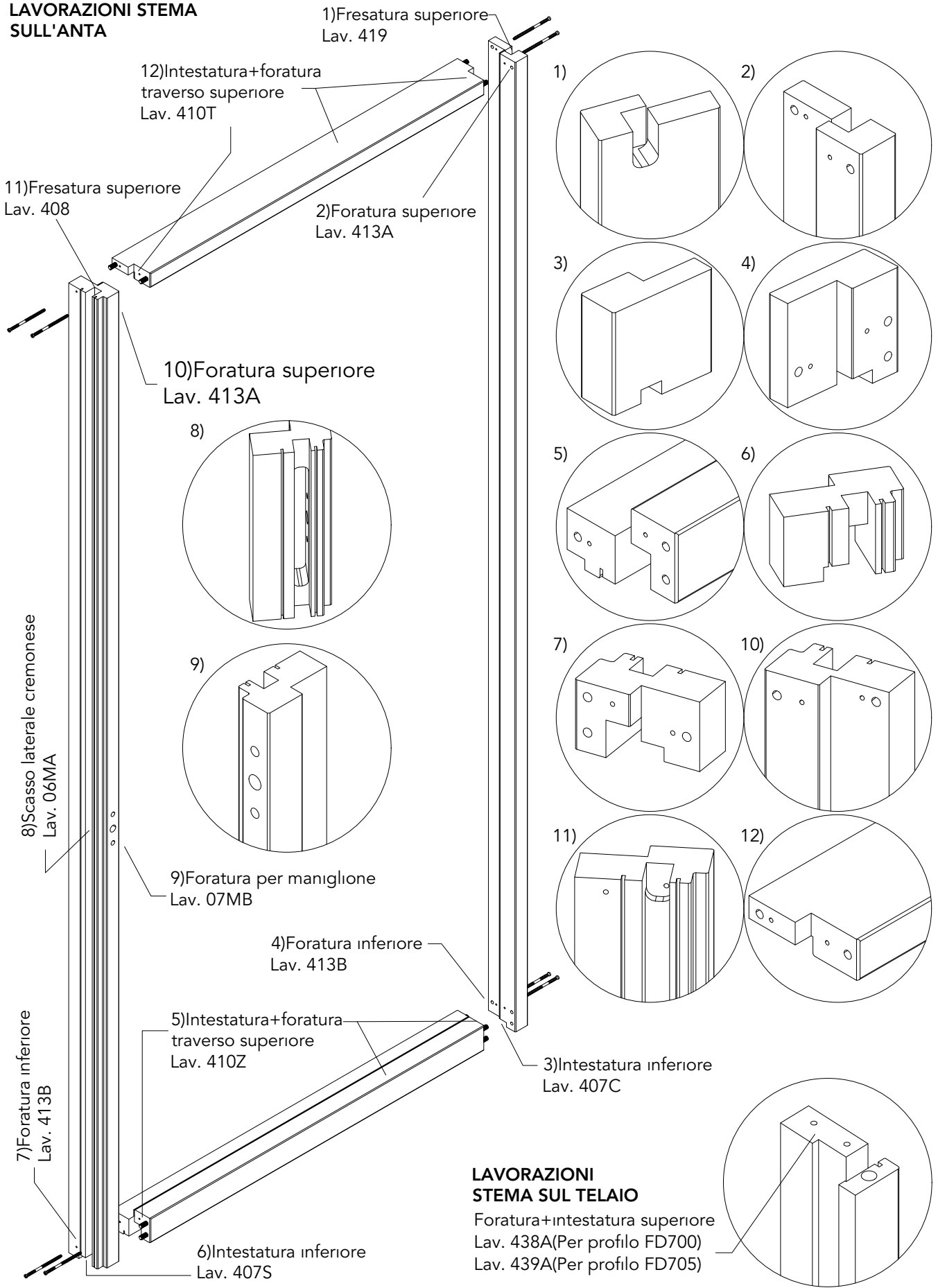

LAVORAZIONI STEMA SUL TELAIO

Foratura+intestatura superiore
 Lav. 438A(Per profilo FD700)
 Lav. 439A(Per profilo FD705)

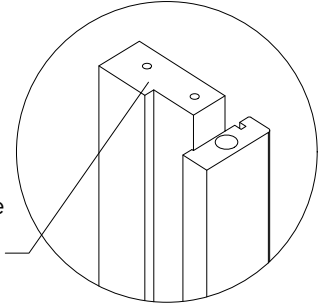

uni_one90° HS magis40



Scala -

- (IT) Profili in legno
- (DE) Holzprofile
- (ES) Perfiles en madera
- (FR) Profils en bois
- (UK) Wood profiles

Profili telaio in alluminio

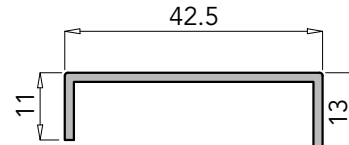
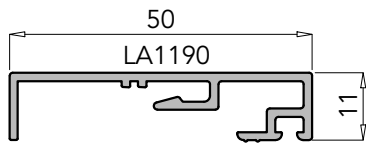
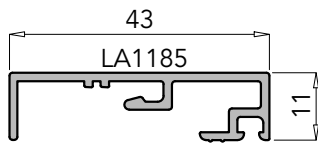
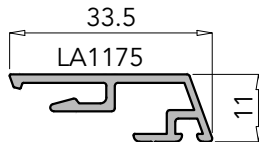
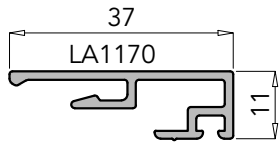

LA1196
Lunghezza barre: 4 mt

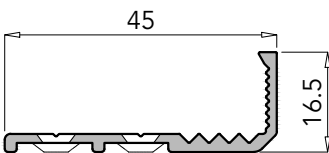
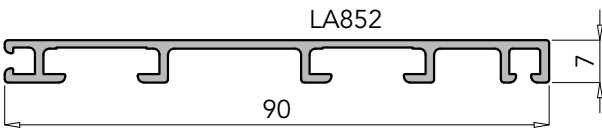
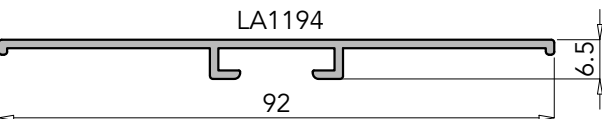
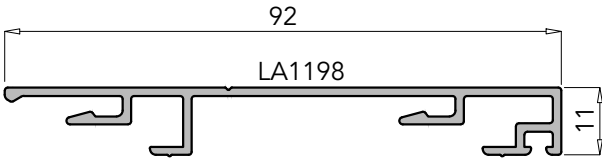

LA688c
Con doppie asole svasate Ø4x8mm passo 200mm sfalsate
Finiture disponibili: Nero RAL9005 opaco
Bianco RAL9016 strutturato

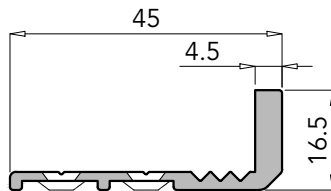

LA694c
Con doppie asole svasate Ø4x8mm passo 200mm sfalsate
Finiture disponibili: Nero RAL9005 opaco
Bianco RAL9016 strutturato

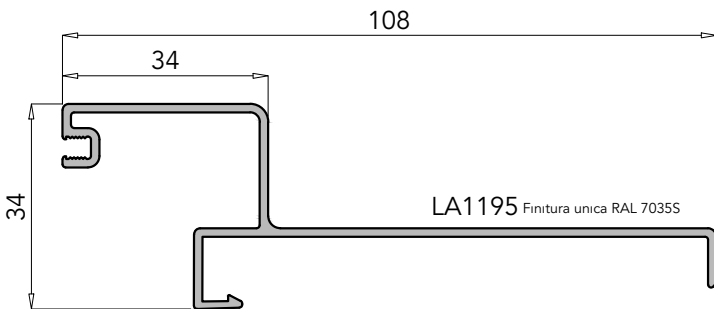

LA1195 Finitura unica RAL 7035S

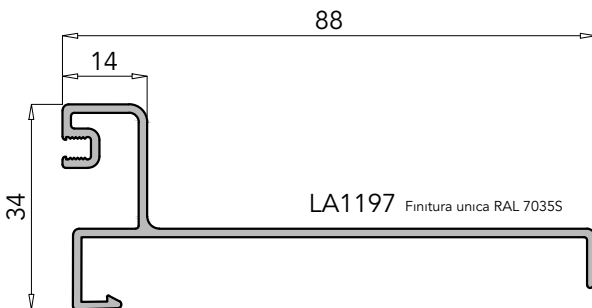

LA1197 Finitura unica RAL 7035S

uni_one90° HS magis40



Scala 0.8:1

- (IT) Profili in alluminio
- (DE) Aluminiumprofile
- (ES) Perfiles en aluminio
- (FR) Profils en aluminium
- (UK) Aluminium profiles

Profili anta in alluminio

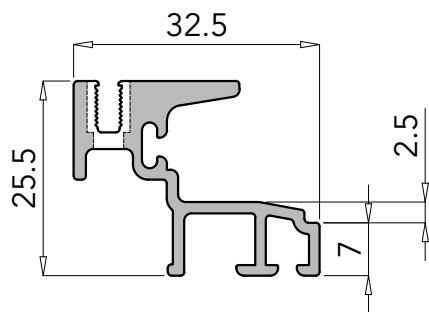

LA1193c

Foratura doppio diametro interasse 300mm

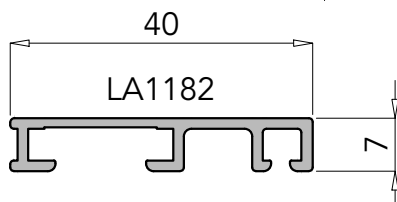

LA1182

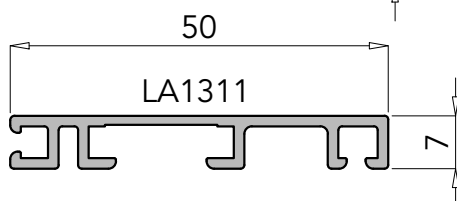

LA1311

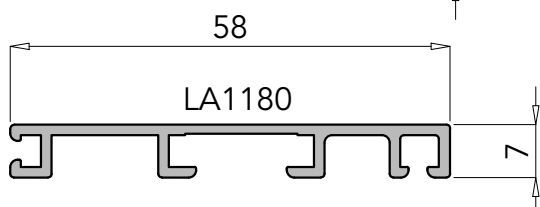

LA1180

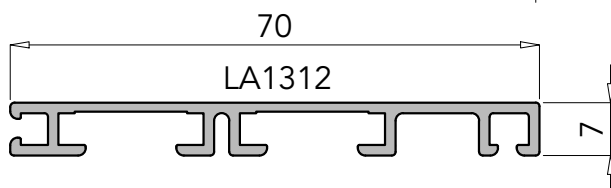

LA1312

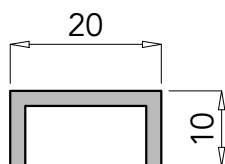

U20X10

Finitura unica RAL 7035S

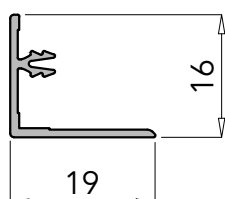

LA669

Finitura unica RAL9005 OPACO
Lunghezza barre: 6-5-3 mt

uni_one90° HS magis40

uniform

Scala 1:1

- (IT) Profili in alluminio
- (DE) Aluminiumprofile
- (ES) Perfiles en aluminio
- (FR) Profils en aluminium
- (UK) Aluminium profiles

Profili complementari

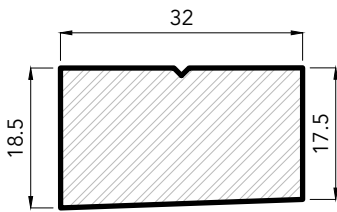

LP219

Materiale: Polietilene rigido
Finitura: Nero
Lunghezza barre: 4 mt

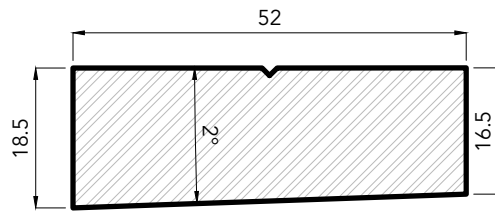

LP214

Materiale: Polietilene rigido
Finitura: Nero
Lunghezza barre: 4 mt

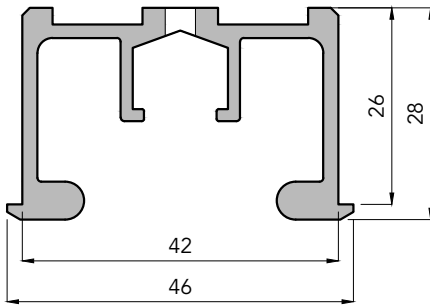

LA1162c

Materiale: Alluminio
Fori Ø4mm passo 200mm
Finitura unica Argento A1K
Lunghezza barre: 6-5-4-3 mt

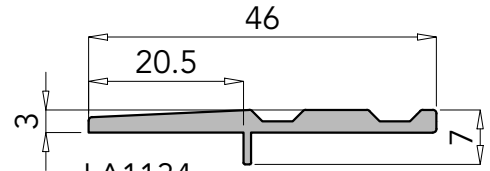

LA1134

Materiale: Alluminio
Finitura unica Argento A1K

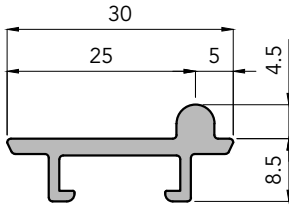

LA1167

Materiale: Alluminio
Finitura unica Argento A1K
Lunghezza barre: 6-5-4-3 mt

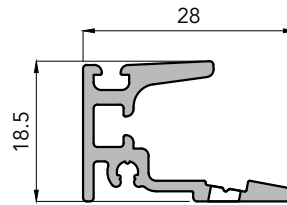

LA1161c

Materiale: Alluminio
Fori Ø4mm interasse 200mm
Finitura unica RAL9005 OPACO
Lunghezza barre: 5 mt

PV199-20

Materiale: Vetroresina
Finitura: Grigio RAL7035
Lunghezza barre: 6-5-4 mt

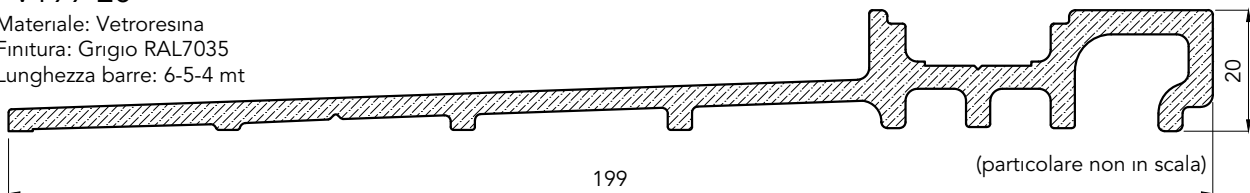

LP199

Materiale: Purenit
Lunghezza barre: 3.6 mt

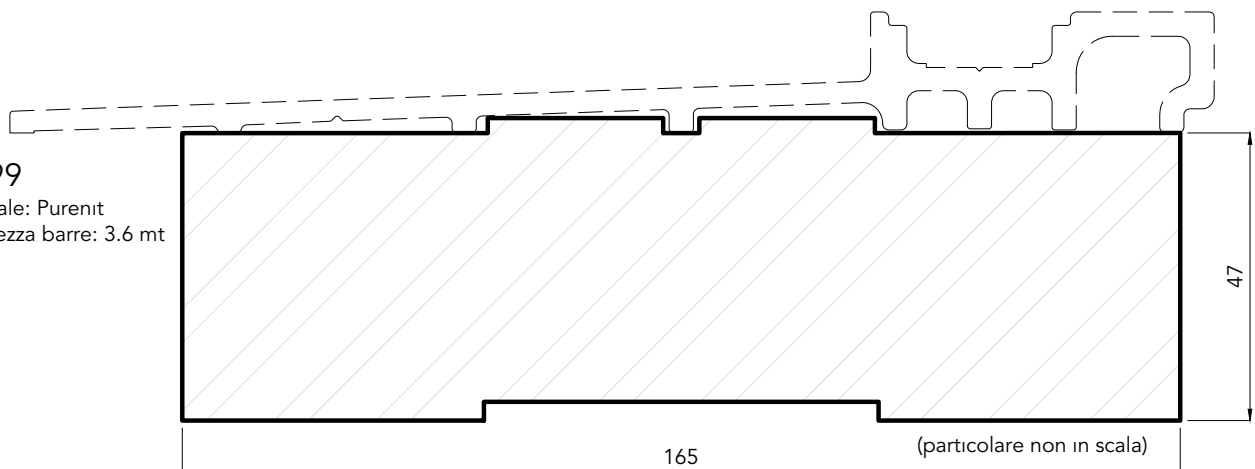

uni_one90° HS magis40

uniform

Scala 1:1

- (IT) Profili in alluminio/Altri profili
- (DE) Aluminiumprofile
- (ES) Perfiles en aluminio
- (FR) Profils en aluminium
- (UK) Aluminium profiles

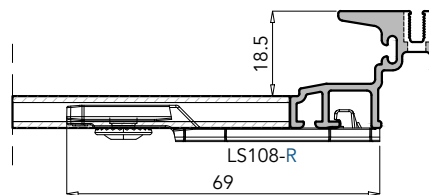
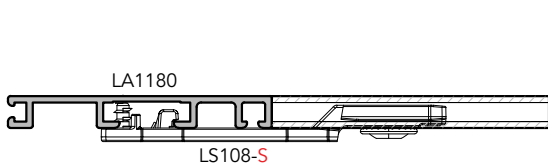
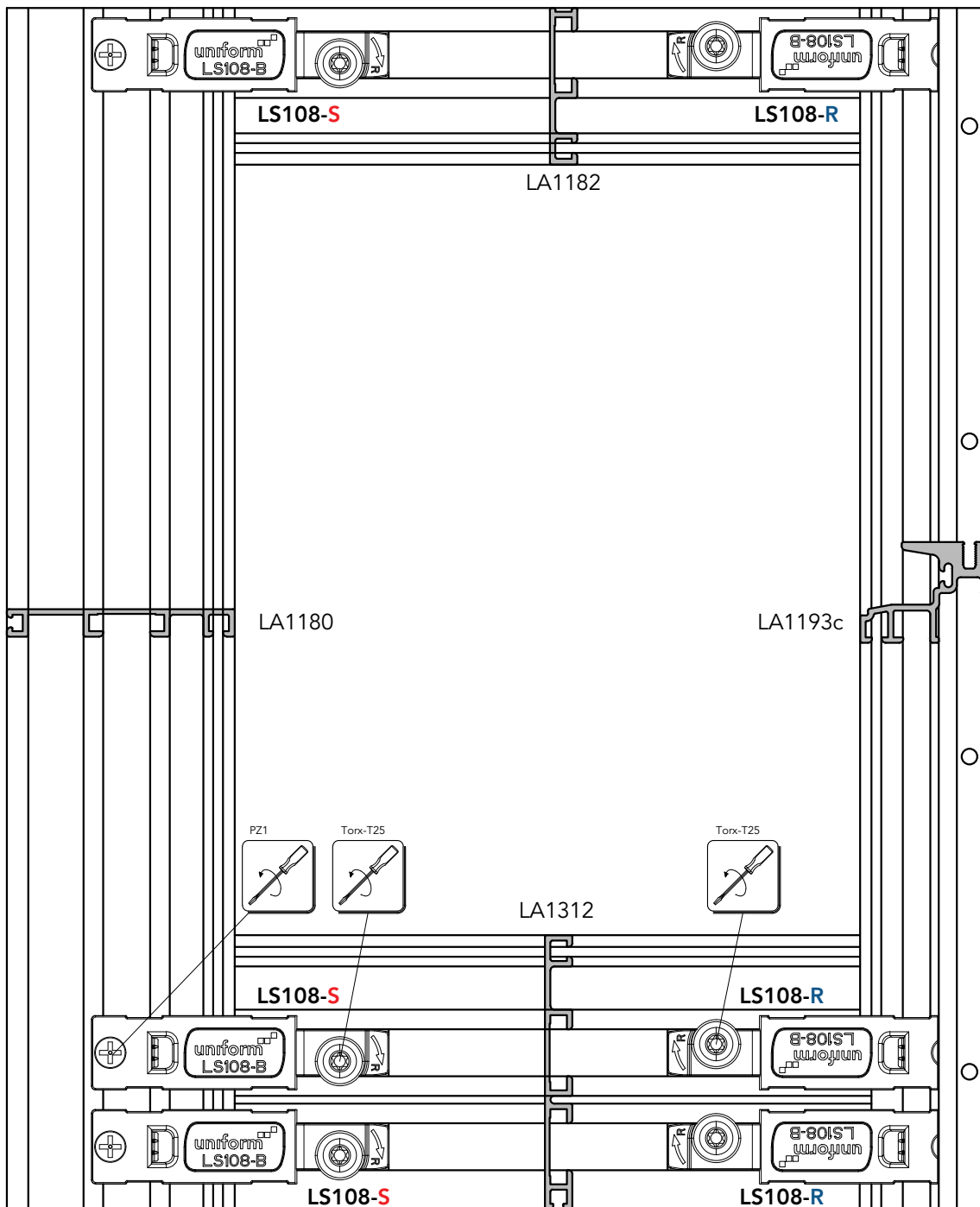

uni_one90° HS magis40



Scala 0.6:1

- (IT) Assemblaggio profili alluminio anta
- (DE) Aluminium profile
- (ES) Perfiles en aluminio
- (FR) Profils en aluminium
- (UK) Aluminium profiles assembly

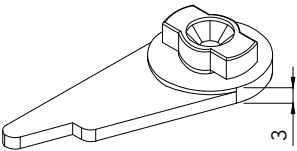
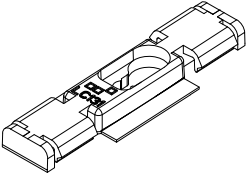
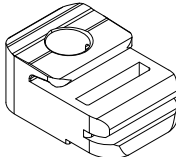
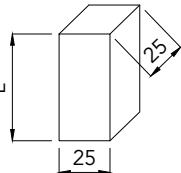
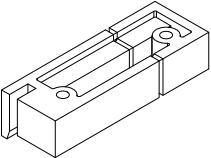
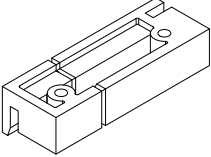
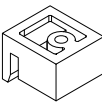
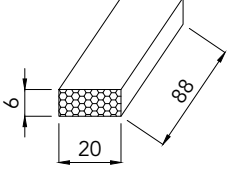
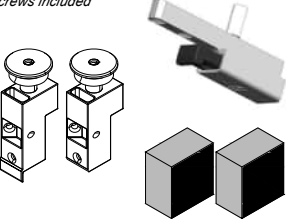
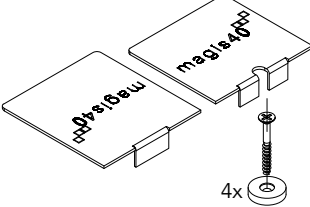
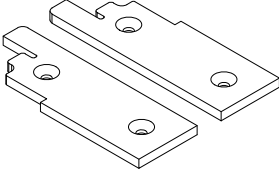
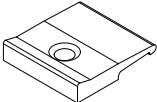
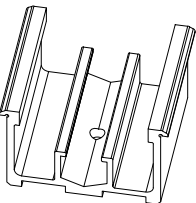
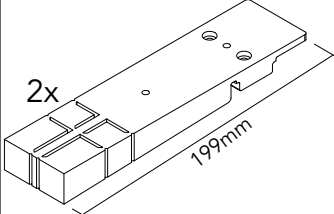
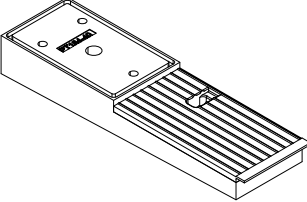
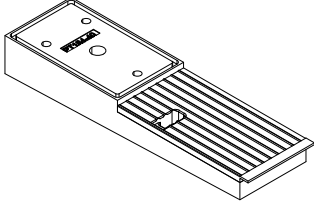
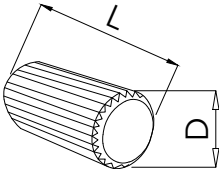
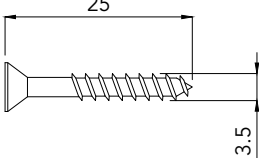
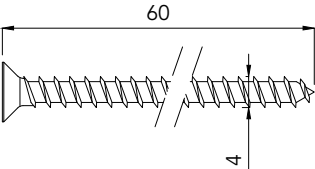
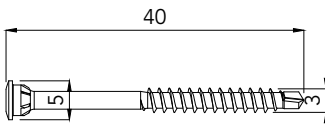

<p>LC5</p>  <p>Materiale/<i>Material</i>: POM Colore/<i>Colour</i>: Nero/Black Clip a vite girevole/<i>Pivot clip</i></p>	<p>LC131</p>  <p>Materiale/<i>Material</i>: Resina acetalica Colore/<i>Colour</i>: Nero/Black Clip a scatto/<i>Snap clip</i></p>	<p>LC175</p> <p>viti incluse <i>screws included</i></p>  <p>Materiale/<i>Material</i>: Nylon Colore/<i>Colour</i>: Nero/Black Clip a vite girevole/<i>Pivot clip</i></p>	<p>LC183-32 L=32mm LC183-52 L=52mm</p>  <p>Materiale/<i>Material</i>: EPDM Colore/<i>Colour</i>: Nero/Black Terminali FD651-FD653/<i>End caps FD651-FD653</i></p>
<p>LC190A-SX</p> <p>viti incluse <i>screws included</i></p>  <p>Materiale/<i>Material</i>: ABS Colore/<i>Colour</i>: Nero/Black Terminale per anta/<i>Endcap</i></p>	<p>LC190A-DX</p> <p>viti incluse <i>screws included</i></p>  <p>Materiale/<i>Material</i>: ABS Colore/<i>Colour</i>: Nero/Black Terminale per anta/<i>Endcap</i></p>	<p>LC190B</p> <p>viti incluse <i>screws included</i></p>  <p>Materiale/<i>Material</i>: ABS Colore/<i>Colour</i>: Nero/Black Terminale per anta/<i>Endcap</i></p>	<p>LC192</p>  <p>Materiale/<i>Material</i>: Neoprene Colore/<i>Colour</i>: Nero/Black Terminale superiore adesivo/<i>Adhesive Endcap</i></p>
<p>LC195</p> <p>viti incluse <i>screws included</i></p>  <p>Materiale/<i>Material</i>: vari Colore/<i>Colour</i>: vari Kit terminali per HS</p>	<p>LC196</p>  <p>Materiale/<i>Material</i>: Acciaio Colore/<i>Colour</i>: Inox Lucido Kit piastre di copertura per anta</p>	<p>LC197</p> <p>viti incluse <i>screws included</i></p>  <p>Materiale/<i>Material</i>: ABS Colore/<i>Colour</i>: Nero/Black Coppia terminali per anta/<i>Endcap</i></p>	<p>LC251</p>  <p>Materiale/<i>Material</i>: Resina acetalica Colore/<i>Colour</i>: Bianco/White Clip a scatto/<i>Clip holder</i></p>
<p>LC1162</p> <p>viti incluse <i>screws included</i></p>  <p>Materiale/<i>Material</i>: Alluminio/Aluminium Colore/<i>Colour</i>: Argento A1K/Silver Terminale per guida LA1162c/<i>Endcap LA1162</i></p>	<p>PT199-20</p>  <p>Materiale/<i>Material</i>: SEBS Colore/<i>Colour</i>: Grigio 7035/Gray 7035 Coppia terminali per soglia/<i>Threshold endcaps</i></p>	<p>PT199-40A-DX</p>  <p>Materiale/<i>Material</i>: SEBS Colore/<i>Colour</i>: Grigio 7035/Gray 7035 Terminale per soglia/<i>Threshold endcaps</i></p>	<p>PT199-40A-SX</p>  <p>Materiale/<i>Material</i>: SEBS Colore/<i>Colour</i>: Grigio 7035/Gray 7035 Terminale per soglia/<i>Threshold endcaps</i></p>
<p>LCS30-8 L=30mm D=8mm LCS40-10 L=40mm D=10mm</p>  <p>Materiale/<i>Material</i>: Legno/Wood Colore/<i>Colour</i>: Grezzo/Raw Tassello/Dowel</p>	<p>LVP25</p>  <p>Materiale/<i>Material</i>: Acciaio zincato/Steel Colore/<i>Colour</i>: Inox Vite 3.5x25mm testa svasata/<i>3.5x25mm Screw</i></p>	<p>LVP60</p>  <p>Materiale/<i>Material</i>: Acciaio zincato/Steel Colore/<i>Colour</i>: Inox Vite 4x60mm testa svasata/<i>4x60mm Screw</i></p>	<p>LVP104N</p>  <p>Materiale/<i>Material</i>: Acciaio zincato/Steel Colore/<i>Colour</i>: Nero/Black Vite 3x40mm testa autof. svasata piana/<i>3x40mm Screw</i></p>

uni_one90° HS magis40

uniform

Scala -

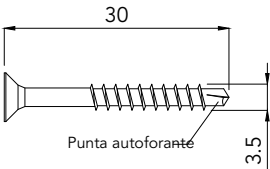
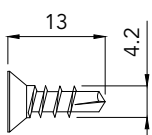
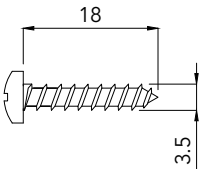
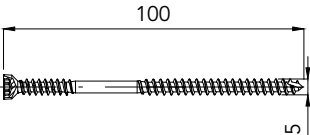
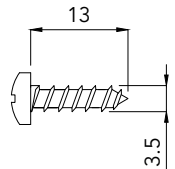
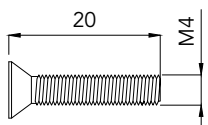
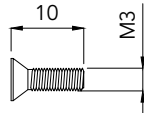
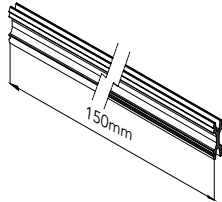
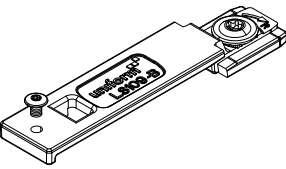
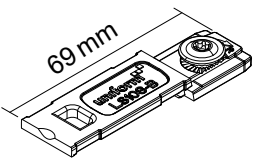
- (IT) Clips di fissaggio e accessori
- (DE) Befestigungsklips und Zubehör
- (ES) Clips de fijación y accesorios
- (FR) Clips de fixation et accessoires
- (UK) Fixing clips and spare-parts

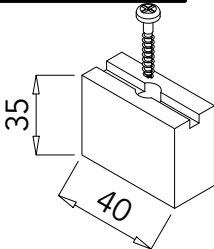
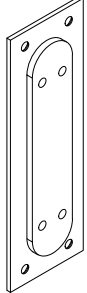
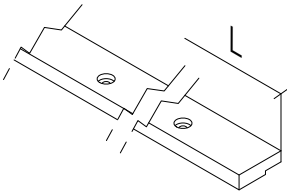
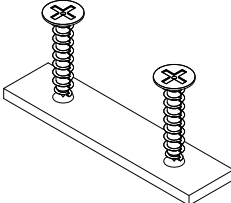
<p>LVP106</p>  <p>Punta autoforante</p> <p>Materiale/Material: Acciaio zincato/Steel Colore/Colour: Inox Vite 3.5x30mm testa svasata piana autoforante/ 3.5x30mm Screw</p>	<p>LVP107</p>  <p>Materiale/Material: Acciaio Inox/Steel Colore/Colour: Nero/Black Vite autofilettante 4.2x13mm svasata/ Self-tapping screw</p>	<p>LVP108</p>  <p>Materiale/Material: Acciaio zincato/Steel Colore/Colour: Inox Vite per LC131-3.5x18mm testa piana/ 3.5x18mm LC131 Screw</p>	<p>LVP120</p>  <p>Materiale/Material: Acciaio zincato/Steel Colore/Colour: Inox Vite 5x100mm giunzione 90°/5x100mm Screw</p>
<p>LVP122</p>  <p>Materiale/Material: Acciaio zincato/Steel Colore/Colour: Inox Vite per LC131-3.5x13mm testa piana/ 3.5x13mm LC131 Screw</p>	<p>LVP123</p>  <p>Materiale/Material: Acciaio zincato/Steel Colore/Colour: Inox Vite autoformante M4x20mm/M4x20mm Screw</p>	<p>LVPM3X10</p>  <p>Materiale/Material: Acciaio zincato/Steel Colore/Colour: Inox Vite filettata M3x10mm/M3x10mm Screw</p>	<p>LS76</p>  <p>Materiale/Material: Alluminio/Aluminium Colore/Colour: Grezzo/Raw Accessorio per fissaggio cornici/Frame fixing accessory</p>
<p>LS108-S</p>  <p>Materiale/Material: Alluminio/Aluminium Colore/Colour: Grezzo/Raw Squadretta assemblaggio traversi/ Crossbar fastener</p>	<p>LS108-R</p>  <p>Materiale/Material: Alluminio/Aluminium Colore/Colour: Grezzo/Raw Squadretta assemblaggio traversi/ Crossbar fastener</p>	<p>LS145</p>  <p>Materiale/Material: Alluminio/Aluminium Colore/Colour: Grezzo/Raw Boccola filettata per fissaggio maniglione</p>	<p>LS148</p>  <p>Materiale/Material: Alluminio/Aluminium Colore/Colour: Grezzo/Raw Squadretta bloccaggio anta/Sash block</p>
<p>LS149</p> <p>viti incluse screws included</p>  <p>Materiale/Material: Alluminio/Aluminium Colore/Colour: Grezzo/Raw Contropiastra per rostro di chiusura a gancio</p>	<p>LS151</p> <p>L= Min. 2500mm Max. 3200mm</p>  <p>Materiale/Material: Acciaio zincato/Steel Colore/Colour: Zincato/Inox Rinforzo in acciaio per FD700-FD705</p>	<p>LS152</p>  <p>Materiale/Material: Alluminio/Aluminium Colore/Colour: Grezzo/Raw Squadretta assemblaggio soglia/ Crossbar fastener</p>	

FS42

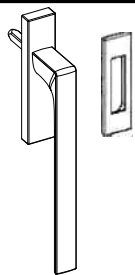

Finiture:
Cromat/Matt Chrome
Biancomat/Matt White
Oroplus/Gold
Cromo/Chrome
Grafitemat/Matt Grafite
Neromat/Matt Black

Kit per maniglione per HS+maniglia ad incasso esterna

FS43

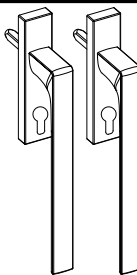

Finiture:
Cromat/Matt Chrome
Biancomat/Matt White
Oroplus/Gold
Cromo/Chrome
Grafitemat/Matt Grafite
Neromat/Matt Black



Cilindro 145mm
European double-profile cylinder
Finitura/Colour: Nichelato/Nickel

Kit maniglione interno/esterno e cilindro

uni_one90° HS magis40

uniform

Scala -

- IT Accessori
- DE Zubehör
- ES Accesorios
- FR Accessoires
- UK Spare-parts

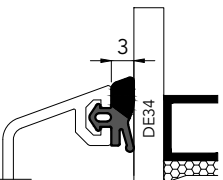
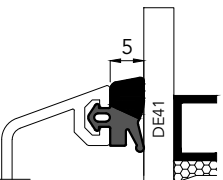
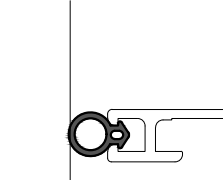
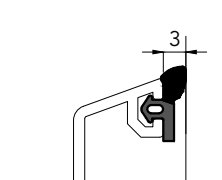
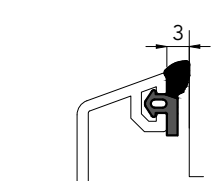
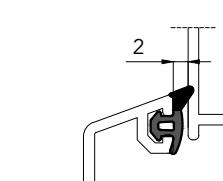
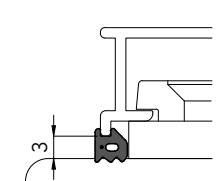
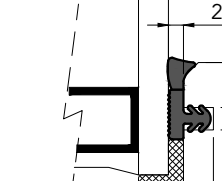
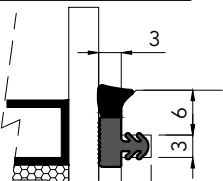
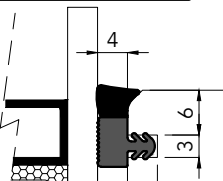
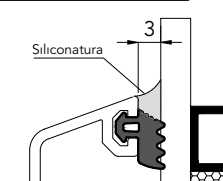
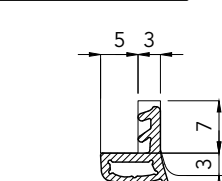
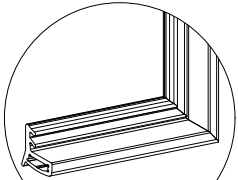
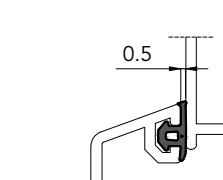
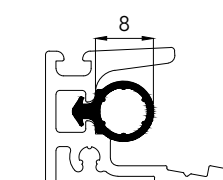
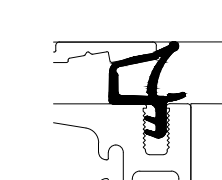
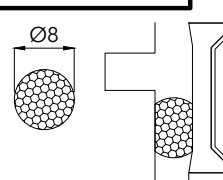
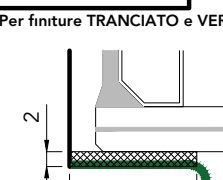
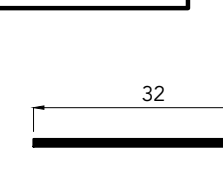
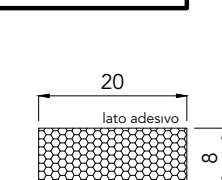







<p>DE34</p>  <p>Materiale/Material: EPDM coestruso Colore/Colour: Nero/Black</p>	<p>DE41</p>  <p>Materiale/Material: EPDM coestruso Colore/Colour: Nero/Black</p>	<p>DE49</p>  <p>Materiale/Material: EPDM Colore/Colour: Nero/Black</p>	<p>DE86</p>  <p>Materiale/Material: EPDM coestruso Colore/Colour: Nero/Black</p>
<p>DE117</p>  <p>Materiale/Material: EPDM coestruso Colore/Colour: Nero/Black</p>	<p>DE125</p>  <p>Materiale/Material: EPDM coestruso Colore/Colour: Nero/Black</p>	<p>DE130</p>  <p>Materiale/Material: EPDM Colore/Colour: Nero/Black</p>	<p>DE132DN</p>  <p>Materiale/Material: EPDM coestruso Colore/Colour: Nero/Black</p>
<p>DE133</p>  <p>Materiale/Material: EPDM coestruso Colore/Colour: Nero/Black</p>	<p>DE134</p>  <p>Materiale/Material: EPDM coestruso Colore/Colour: Nero/Black</p>	<p>DE146</p>  <p>Materiale/Material: EPDM Colore/Colour: Nero/Black</p>	<p>DE173</p>  <p>Materiale/Material: EPDM Colore/Colour: Nero/Black</p>
<p>DE173-E Angolo vulcanizzato DE173 Misura: 2.5x2.5mt</p>  <p>Materiale/Material: EPDM Colore/Colour: Nero/Black Guarnizione(Dx-Sx) angolo vulcanizzato</p>	<p>DE174</p>  <p>Materiale/Material: EPDM Colore/Colour: Nero/Black</p>	<p>DE176</p>  <p>Materiale/Material: Silicone/Silicon Colore/Colour: Nero/Black</p>	<p>DE181S</p>  <p>Materiale/Material: Silicone/Silicon Colore/Colour: Nero/Black</p>
<p>FG08</p>  <p>Materiale/Material: Polietileno espanso Colore/Colour: Grigio/Gray</p>	<p>LCN20-2BT Per finiture TRANCIATO e VERNICIATO</p>  <p>Materiale/Material: Biadesivo/ Biadhesive tape Colore/Colour: Nero/Black</p>	<p>LCN32-1N</p>  <p>Materiale/Material: Biadesivo/ Biadhesive tape Colore/Colour: Nero/Black</p>	<p>LG20-4P</p>  <p>Materiale/Material: Polietileno espanso Colore/Colour: Grigio/Gray</p>

uni_one90° HS magis40

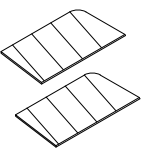
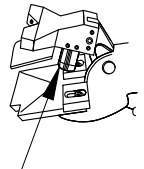
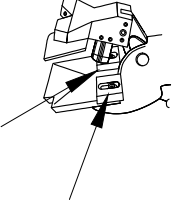
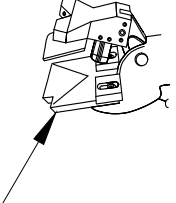
uniform

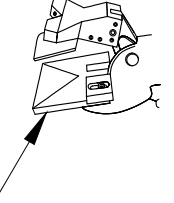
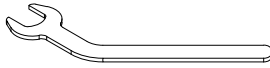
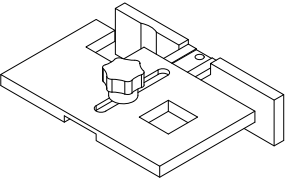
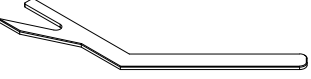
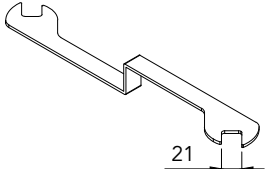
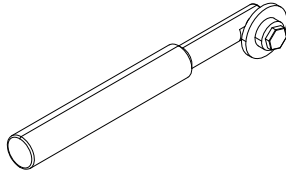
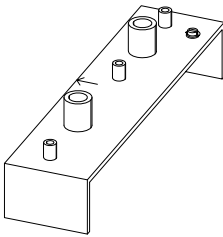
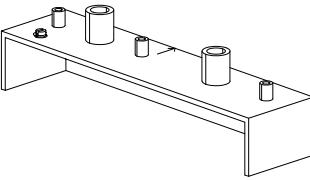
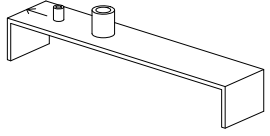
Scala -

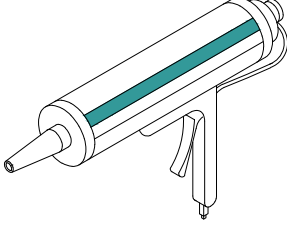
- (IT) Guarnizioni
- (DE) Dichtung
- (ES) Juntas
- (FR) Joints
- (UK) Gaskets

<p>LF1</p>  <p>Forbice per il taglio delle guarnizioni/<i>Scissor for cutting the gaskets</i></p>	<p>LF2</p>  <p>Forbice per taglio a 45° delle guarnizioni/<i>Scissor for cutting 45° the gaskets</i></p>	<p>LF2A</p>  <p>Coppia di lame per LF2 e LF4/<i>Pair of blades for LF2 and LF4</i></p>	<p>LF2B</p>  <p>Inserto sagomato di ricambio per LF2/<i>Upper blade for LF2</i></p>
<p>LF2C</p>  <p>Coppia di blocchetti di riscontro per LF2 e LF4/<i>Teflon support for LF2</i></p>	<p>LF2D</p>  <p>Base in Teflon di ricambio per LF2/<i>Teflon support for LF2</i></p>	<p>LF4</p>  <p>Forbice per taglio a 45° delle guarnizioni sull'anta/<i>Scissor for cutting 45° the gasket on the sash</i></p>	<p>LF4D</p>  <p>Base in Teflon di ricambio per LF4/<i>Teflon support for LF4</i></p>
<p>LD46</p>  <p>Materiale/<i>Material</i>: Acciaio/<i>Steel</i> Chiave per clips: LC26-LC50-LC62-LC80/<i>Wrench for clips LC26-LC50-LC62-LC80</i></p>	<p>LD48</p>  <p>Materiale/<i>Material</i>: Alluminio/<i>Aluminium</i> Dima regolabile per LC26-LC50/<i>Adjustable template for positioning LC26-LC50</i></p>	<p>LD66</p>  <p>Materiale/<i>Material</i>: Acciaio/<i>Steel</i> Chiave per clips LC5/<i>Wrench for clips LC5</i></p>	<p>LD67</p>  <p>Materiale/<i>Material</i>: Acciaio/<i>Steel</i> Chiave per clips LC175/<i>Wrench for pivot clips LC175</i></p>
<p>LD69</p>  <p>Materiale/<i>Material</i>: Vari Dima per inserimento fondogiunto/<i>Template for FG08</i></p>	<p>LD72DX</p>  <p>Materiale/<i>Material</i>: Acciaio/<i>Steel</i> Dima per foratura/<i>Template</i></p>	<p>LD72SX</p>  <p>Materiale/<i>Material</i>: Acciaio/<i>Steel</i> Dima per foratura/<i>Template</i></p>	<p>LD73</p>  <p>Materiale/<i>Material</i>: Acciaio/<i>Steel</i> Dima per foratura/<i>Template</i></p>
<p>DC-S600</p>  <p>Colla per l'incollaggio strutturale legno-vetro/<i>Alu+glass bonding glue</i></p>	<p>GB-EROGATORE</p>  <p>Erogatore pneumatico per colla GB-S600/<i>Pneumatic dispenser</i></p>	<p>LC-RE</p>  <p>Colla cianoacrilica per l'incollaggio di guarnizioni in EPDM/<i>Glue for EPDM gaskets</i></p>	<p>SP101T</p>  <p>Sigillante/<i>Sealant</i></p>

uni_one90° HS magis40

uniform

Scala -

- IT Accessori e attrezzature
- DE Zubehör und Werkzeuge
- ES Accesorios y utiles
- FR Accessoires et outillages
- UK Spare-parts and tools

Finitura NATURA	LCR-50	Vernice ritocco finitura TR001-PL021-TN041/ <i>Varnish touch-up paint TR001-PL021-TN041</i>
	LCR-51	Vernice ritocco finitura TR002-PL022-TN042/ <i>Varnish touch-up paint TR002-PL022-TN042</i>
	LCR-52	Vernice ritocco finitura TR003-PL023-TN043/ <i>Varnish touch-up paint TR003-PL023-TN043</i>
	LCR-53	Vernice ritocco finitura TR004/ <i>Varnish touch-up paint TR004</i>
	LCR-54	Vernice ritocco finitura TR015/ <i>Varnish touch-up paint TR015</i>
	LCR-55	Vernice ritocco finitura TR016/ <i>Varnish touch-up paint TR016</i>
	LCR-56	Vernice ritocco finitura TR017/ <i>Varnish touch-up paint TR017</i>
	LCR-57	Vernice ritocco finitura TR018/ <i>Varnish touch-up paint TR018</i>
Finitura ICONA	LCR60	Vernice ritocco finitura IC050/ <i>Varnish touch-up paint IC050-IC059</i>
	LCR75	Vernice ritocco finitura IC051/ <i>Varnish touch-up paint IC051</i>
	LCR76	Vernice ritocco finitura IC052/ <i>Varnish touch-up paint IC052</i>
	LCR77	Vernice ritocco finitura IC053/ <i>Varnish touch-up paint IC053</i>
	LCR78	Vernice ritocco finitura IC054/ <i>Varnish touch-up paint IC054</i>
	LCR79	Vernice ritocco finitura IC055/ <i>Varnish touch-up paint IC055</i>
	LCR80	Vernice ritocco finitura IC056/ <i>Varnish touch-up paint IC056</i>
	LCR81	Vernice ritocco finitura IC057/ <i>Varnish touch-up paint IC057</i>
	LCR82	Vernice ritocco finitura IC058/ <i>Varnish touch-up paint IC058</i>
	LCR60	Vernice ritocco finitura IC059/ <i>Varnish touch-up paint IC059</i>
	LCR83	Vernice ritocco finitura IC060/ <i>Varnish touch-up paint IC060</i>

Finitura <i>Finish</i> ICONA	Descrizione <i>Description</i>	Codice pennarello <i>Touch up pen ref. id</i>	
IC 050	FINITURA SALE	LCPEN13	
IC 051	FINITURA PERLA	LCPEN14	
IC 052	FINITURA ROCCIA	LCPEN15	
IC 053	FINITURA CORDA	LCPEN16	
IC 054	FINITURA GRANO	LCPEN17	
IC 055	FINITURA CORTECCIA	LCPEN18	
IC 056	FINITURA TORBA	LCPEN19	
IC 057	FINITURA LAVICA	LCPEN20	
IC 058	FINITURA RUGGINE	LCPEN21	
IC 059	FINITURA TALCO	LCPEN13	
IC 060	FINITURA QUERCIA	LCPEN16	

Nell'interesse di un continuo miglioramento dei prodotti, Uniform spa si riserva il diritto di variare le specifiche in qualsiasi momento senza previa notifica.

In the interest of continued improvements to the products, Uniform spa reserve the right to change specifications at any time and without prior notification, and without any obligation

uniform
thewindowmotive®